

# HL Paper 2

Rhodium-106 ( $^{106}_{45}\text{Rh}$ ) decays into palladium-106 ( $^{106}_{46}\text{Pd}$ ) by beta minus ( $\beta^-$ ) decay. The diagram shows some of the nuclear energy levels of rhodium-106 and palladium-106. The arrow represents the  $\beta^-$  decay.

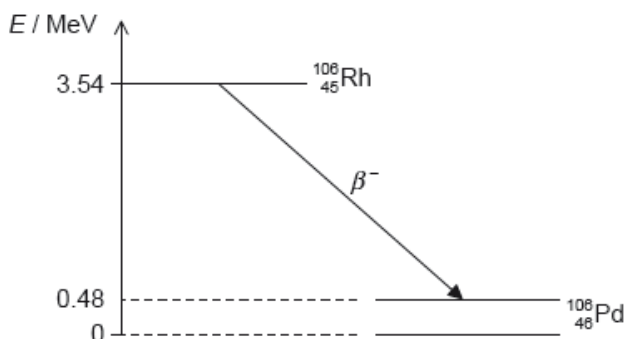

b. Bohr modified the Rutherford model by introducing the condition  $mvr = n \frac{h}{2\pi}$ . Outline the reason for this modification. [3]

c.i. Show that the speed  $v$  of an electron in the hydrogen atom is related to the radius  $r$  of the orbit by the expression [1]

$$v = \sqrt{\frac{ke^2}{m_e r}}$$

where  $k$  is the Coulomb constant.

c.ii. Using the answer in (b) and (c)(i), deduce that the radius  $r$  of the electron's orbit in the ground state of hydrogen is given by the following expression. [2]

$$r = \frac{h^2}{4\pi^2 k m_e e^2}$$

c.iii. Calculate the electron's orbital radius in (c)(ii). [1]

d.i. Explain what may be deduced about the energy of the electron in the  $\beta^-$  decay. [3]

d.ii. Suggest why the  $\beta^-$  decay is followed by the emission of a gamma ray photon. [1]

d.iii. Calculate the wavelength of the gamma ray photon in (d)(ii). [2]

## Markscheme

b. the electrons accelerate and so radiate energy

they would therefore spiral into the nucleus/atoms would be unstable

electrons have discrete/only certain energy levels

the only orbits where electrons do not radiate are those that satisfy the Bohr condition « $mvr = n \frac{h}{2\pi}$ »

[3 marks]

c.i.  $\frac{m_e v^2}{r} = \frac{ke^2}{r^2}$

**OR**

KE =  $\frac{1}{2}$ PE hence  $\frac{1}{2} m_e v^2 = \frac{1}{2} \frac{ke^2}{r}$

«solving for  $v$  to get answer»

*Answer given – look for correct working*

**[1 mark]**

c.ii.combining  $v = \sqrt{\frac{ke^2}{m_e r}}$  with  $m_e v r = \frac{h}{2\pi}$  using correct substitution

«eg  $m_e^2 \frac{ke^2}{m_e r} r^2 = \frac{h^2}{4\pi^2}$ »

correct algebraic manipulation to gain the answer

*Answer given – look for correct working*

*Do not allow a bald statement of the answer for MP2. Some further working eg cancellation of  $m$  or  $r$  must be shown*

**[2 marks]**

c.iii «  $r = \frac{(6.63 \times 10^{-34})^2}{4\pi^2 \times 8.99 \times 10^9 \times 9.11 \times 10^{-31} \times (1.6 \times 10^{-19})^2}$  »

$r = 5.3 \times 10^{-11}$  «m»

**[1 mark]**

d.i.the energy released is  $3.54 - 0.48 = 3.06$  «MeV»

this is shared by the electron and the antineutrino

so the electron's energy varies from 0 to 3.06 «MeV»

**[3 marks]**

d.ii.the palladium nucleus emits the photon when it decays into the ground state «from the excited state»

**[1 mark]**

d.iii.Photon energy

$E = 0.48 \times 10^6 \times 1.6 \times 10^{-19} = \text{«}7.68 \times 10^{-14} \text{ J»}$

$\lambda = \text{«} \frac{hc}{E} = \frac{6.63 \times 10^{-34} \times 3 \times 10^8}{7.68 \times 10^{-14}} \Rightarrow 2.6 \times 10^{-12} \text{ «m»}$

*Award [2] for a bald correct answer*

*Allow ECF from incorrect energy*

**[2 marks]**

## Examiners report

b. [N/A]

c.i. [N/A]

c.ii. [N/A]

c.iii. [N/A]

d.i. [N/A]

d.ii. [N/A]

d.iii. [N/A]

An ohmic conductor is connected to an ideal ammeter and to a power supply of output voltage  $V$ .

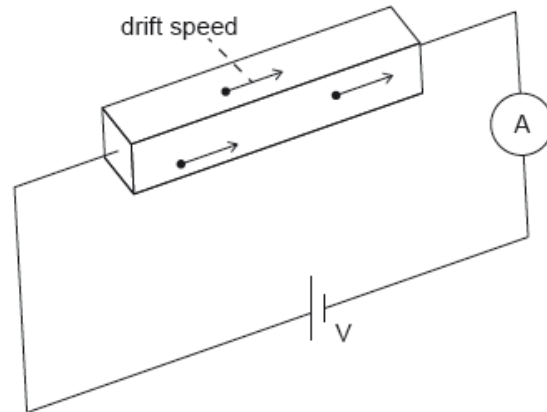

The following data are available for the conductor:

density of free electrons  $= 8.5 \times 10^{22} \text{ cm}^{-3}$

resistivity  $\rho = 1.7 \times 10^{-8} \Omega\text{m}$

dimensions  $w \times h \times l = 0.020 \text{ cm} \times 0.020 \text{ cm} \times 10 \text{ cm}$ .

The ammeter reading is 2.0 A.

The electric field  $E$  inside the sample can be approximated as the uniform electric field between two parallel plates.

b. Calculate the drift speed  $v$  of the electrons in the conductor in  $\text{cm s}^{-1}$ .

[2]

c.i. Determine the electric field strength  $E$ .

[2]

c.ii. Show that  $\frac{v}{E} = \frac{1}{ne\rho}$ .

[3]

## Markscheme

b.  $v \ll \frac{I}{neA} = \frac{2}{8.5 \times 10^{22} \times 1.60 \times 10^{-19} \times 0.02^2}$

0.37 « $\text{cm s}^{-1}$ »

[2 marks]

c.i.  $V = RI = 0.086 \text{ «V»}$

« $\frac{V}{d} = \frac{0.086}{0.10} \Rightarrow 0.86 \text{ «V m}^{-1}$ »

Allow ECF from 4(a).

Allow ECF from MP1.

[2 marks]

c.ii. **ALTERNATIVE 1**

clear use of Ohm's Law ( $V = IR$ )

clear use of  $R = \frac{\rho L}{A}$

combining with  $I = nAve$  and  $V = EL$  to reach result.

**ALTERNATIVE 2**

attempts to substitute values into equation.

correctly calculates LHS as  $4.3 \times 10^9$ .

correctly calculates RHS as  $4.3 \times 10^9$ .

**For ALTERNATIVE 1 look for:**

$$V = IR$$

$$R = \frac{\rho L}{A}$$

$$V = EL$$

$$I = nAve$$

$$V = I \frac{\rho L}{A}$$

$$EL = I \frac{\rho L}{A}$$

$$E = I \frac{\rho}{A}$$

$$E = nAve \frac{\rho}{A} = nve\rho$$

$$\frac{v}{E} = \frac{1}{ne\rho}$$

[3 marks]

## Examiners report

b. [N/A]

c.i. [N/A]

c.ii. [N/A]

The diagram shows a potential divider circuit used to measure the emf  $E$  of a cell X. Both cells have negligible internal resistance.

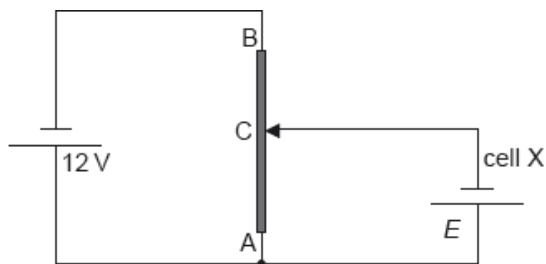

Cell X is replaced by a second cell of identical emf  $E$  but with internal resistance  $2.0 \Omega$ . Comment on the length of AC for which the current in the second cell is zero.

# Markscheme

since the current in the cell is still zero there is no potential drop across the internal resistance

and so the length would be the same

OWTTE

[2 marks]

# Examiners report

[N/A]

This question is in **two** parts. **Part 1** is about electrical circuits. **Part 2** is about magnetic

fields.

## Part 1 Electrical circuits

The circuit shown is used to investigate how the power developed by a cell varies when the load resistance  $R$  changes.

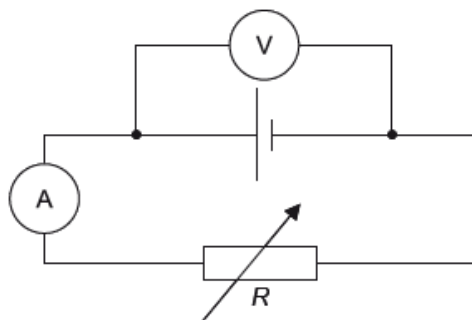

The variable resistor is adjusted and a series of current and voltage readings are taken.

The graph shows the variation with  $R$  of the power dissipated in the cell and the power dissipated in the variable resistor.

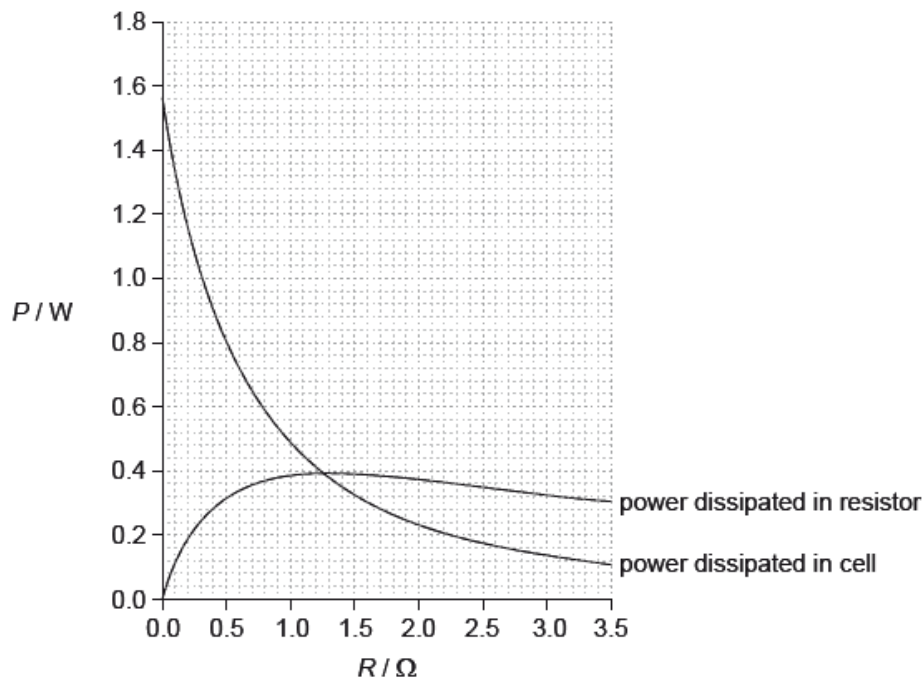

This question is in **two** parts. **Part 1** is about electrical circuits. **Part 2** is about magnetic fields.

**Part 2** Magnetic fields

The diagram shows an arrangement for measuring the force between two parallel sections of the same rigid wire carrying a current as viewed from the front.

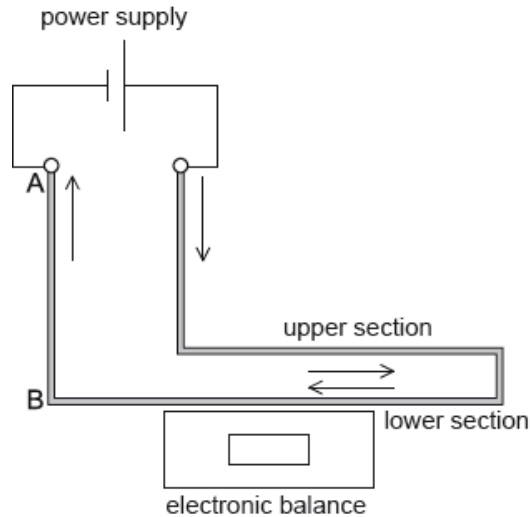

The supports for the upper section of the wire and the power supply are not shown.

When the current in the wire is 0.20 A, the magnetic field strength at the upper section of wire due to the lower section of wire is  $1.3 \times 10^{-4}$  T.

- d. The cell may be damaged if it dissipates a power greater than 1.2 W. Outline why damage in the cell may occur if the terminals of the cell are short-circuited. [2]
- e. The part of the wire from A to B is viewed from above. The direction of the current is out of the plane of the paper. [2]  
Using the diagram, draw the magnetic field pattern due to just the current in wire AB.
- f. Deduce what happens to the reading on the electronic balance when the current is switched on. [3]

g.i. Calculate the magnetic force acting per unit length on the upper section of wire.

[1]

g.ii. Each cubic metre of the wire contains approximately  $8.5 \times 10^{28}$  free electrons. The diameter of the wire is 2.5 mm and the length of wire within the magnetic field is 0.15 m. Using the force per unit length calculated in (g)(i), deduce the speed of the electrons in the wire when the current is 0.20 A.

h. The upper section of wire is adjusted to make an angle of  $30^\circ$  with the lower section of wire. Outline how the reading of the balance will change, if at all.

## Markscheme

d. in this case  $R = 0$  / total resistance is internal resistance;

power dissipated is greater than 1.2 W / power dissipated is 1.56 (W) which is larger than limit; } (*must be quantitative not "it's too big"*)

e. minimum of two concentric circles;

three circles, centered on wire with separation increasing with distance from the wire;

minimum of one arrow showing anticlockwise;

f. magnetic field due to upper wire on lower wire horizontal and into page;

shows force is downwards by any valid rule; (*allow ECF from "out of page"*)

reading of balance increases; (*allow ECF*)

**or**

currents are antiparallel / in opposite directions;

so wires repelled (by any argument giving force direction);

reading of balance increases;

g.i.  $2.6 \times 10^{-5}$  (Nm<sup>-1</sup>);

g.ii. volume of wire =  $\pi \times \frac{(2.5 \times 10^{-3})^2}{4} \times 0.15$  (=  $7.36 \times 10^{-7}$  m<sup>3</sup>);

charge in wire =  $8.5 \times 10^{28} \times 7.36 \times 10^{-7} \times 1.6 \times 10^{-19}$  (=  $10 \times 10^3$  C);

$$v = \frac{F}{Bq} = \frac{3.9 \times 10^{-6}}{1.3 \times 10^{-4} \times 10^4};$$

$3.0 \mu\text{m s}^{-1}$ ; (*allow ECF from (g)(i)*)

**N.B.:** answer should be  $0.115 \times$  their (g)(i).

*Confusing diameter with radius gives answer of  $0.75 \mu\text{m s}^{-1}$  – award [3 max].*

*Award [4] for a bald correct answer.*

h. parts of the wire will experience a smaller magnetic field;

and hence a smaller force;

so the reading of the balance will decrease / OWTTE;

## Examiners report

- d. A considerable lack of thought was in evidence in this part. The correct answer can be stated baldly: *a short circuit means that  $R$  is zero and therefore the emf of the cell acts on the circuit and the power acting can be read directly from the graph as about 1.5 W. It is greater than 1.2 W and will therefore damage the cell.* Few managed to answer in such a direct or convincing way. Most used weasel words that simply repeated the first sentence of the question back to the examiner in an alternative way.
- e. While very many candidates scored a maximum 2 out of 2 marks for this part, this was only because there were 3 marks available. Circles were rarely circular – most were freehand sketches (do modern candidates not possess drawing instruments?). It was rare to see accurate drawings that showed a clear greater line spacing as the distance from the wire increased.
- f. Many scored 2 out to 3 in this part through failing to give the direction rule (first alternative in the mark scheme) by which they assigned the force on the bottom wire. The second alternative attracted maximum marks for many.
- g.i. This simple calculation was well done. The unit, however, was frequently incorrect (not a marking point).
- g.ii. Only a handful of candidates were able to work this problem through. Significant hurdles for many included: failure to calculate the volume of the wire (not just a radius/diameter confusion, a genuine inability to operate  $l\pi r^2$  convincingly), inability to include the charge on the electron correctly, and an apparent misunderstanding of the operating equation with trigonometric functions appearing out of the blue.
- h. Many simply stated the answer without any rigorous explanation of the causal links and therefore scored a generous one mark for what might have been close to a guess (had the option of “no change” not been available).

## Part 2 Power transmissions

The diagram shows the main features of an ideal transformer whose primary coil is connected to a source of alternating current (ac) voltage.

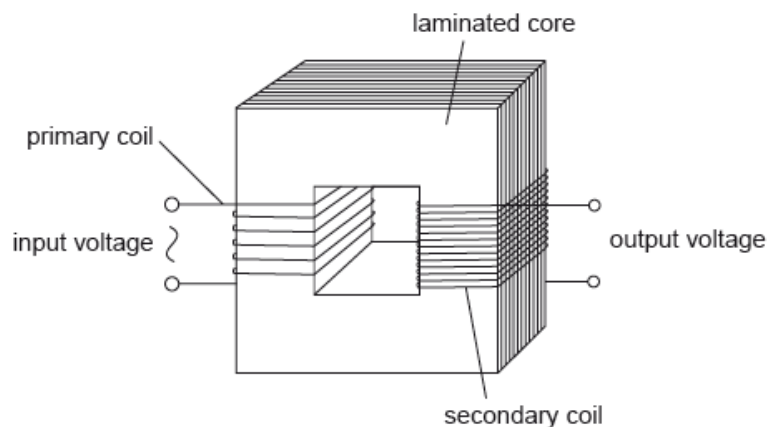

A different transformer is used to transmit power to a small town.

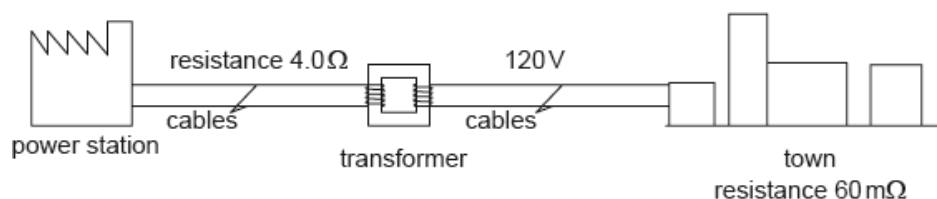



The transmission cables from the power station to the transformer have a total resistance of  $4.0 \Omega$ . The transformer is 90% efficient and steps down the voltage to 120 V. At the time of maximum power demand the effective resistance of the town and of the cables from the transformer to the town is  $60 \text{ m}\Omega$ .

- d. Outline, with reference to electromagnetic induction, how a voltage is induced across the secondary coil. [3]
- e. The primary coil has 25 turns and is connected to an alternating supply with an input voltage of root mean squared (rms) value 12 V. The secondary coil has 80 turns and is not connected to an external circuit. Determine the peak voltage induced across the secondary coil. [2]
- f.i. Calculate the current in the cables connected to the town [1]
- f.ii. Calculate the power supplied to the transformer. [2]
- f.iii. Determine the input voltage to the transformer if the power loss in the cables from the power station is 2.0 kW. [2]
- g. Outline why laminating the core improves the efficiency of a transformer. [2]

## Markscheme

- d. (alternating) pd/voltage across primary coil leads to (alternating) current (in primary coil);

hence there is a changing/alternating magnetic field in primary;

leading to a changing magnetic flux linked to/appearing in secondary;

according to Faraday's law, an alternating emf is induced in the secondary coil;

- e. rms secondary voltage =  $38.4 \text{ (V)}$ ;

peak voltage =  $(38\sqrt{2} =) 54 \text{ (V)}$ ; (allow ECF from MP1)

Award [2] for a bald correct answer.

- f.i.  $(I_s = \frac{120}{60 \times 10^{-3}}) = 2.0 \text{ k(A)}$ ; (30 A is a common and incorrect answer)

- f.ii. power (supplied to town) =  $2.0 \times 10^3 \times 120$  or  $2.4 \times 10^5$ ; (allow ECF from (f)(i))

power (supplied to transformer) =  $(\frac{2.4 \times 10^5}{0.9} =) 2.67 \times 10^5 \text{ (W)}$ ; } (30 A in (f)(i) leads to 4 kW)

Award [2] for a bald correct answer.

- f.iii.  $I_p = \sqrt{\frac{2 \times 10^3}{4.0}} = 22.4 \text{ (A)}$ ;

$V = \frac{P}{I} = \frac{2.67 \times 10^5}{22.4} = 12 \text{ k(V)}$ ;

Allow ECF from (f)(i) and (f)(ii).

30 A and 4 kW earlier leads to 179 V.

Award [2] for a bald correct answer.

- g. laminations increase resistance / reduce current in core material/metal / reduce eddy currents;

thus reducing  $I^2 R$ /power/(thermal) energy/heat losses in the core;

## Examiners report

- d. In the second part of this question, candidates showed themselves to be much less confident with ideas of electromagnetic induction. Discussion of induction of the secondary emf in the transformer ought to be well rehearsed and confident from a candidate at this level. Instead, examiners were treated to incomplete and often non-physical descriptions. Standard and expected terminology was rare. Terms such as magnetic flux, linking, emf and induction were either omitted or misused. This is clearly an area where there is much misunderstanding.
- e. On the other hand, candidates were well able to cope with the (straightforward) calculation of the induced emf across the secondary coil. However, a frequent omission was the final conversion to a peak value.
- f.i. This whole sequence of calculations was poorly done. Candidates appear never to have considered the problem of energy loss in the cabling between energy generator and consumer. This ought to be straightforward work for the candidates, but it proved not to be. Solutions as a whole were confused with little clear explanation of what was going on. Candidates were evaluating the wrong quantities without realising it and then misapplying them later in the question. As an example, simply labelling a quantity as “*Power = ...*” is unhelpful. What power is being referred to by the candidate? The argument *must* be clear in order that an examiner can award error carried forward.
- f.ii. This whole sequence of calculations was poorly done. Candidates appear never to have considered the problem of energy loss in the cabling between energy generator and consumer. This ought to be straightforward work for the candidates, but it proved not to be. Solutions as a whole were confused with little clear explanation of what was going on. Candidates were evaluating the wrong quantities without realising it and then misapplying them later in the question. As an example, simply labelling a quantity as “*Power = ...*” is unhelpful. What power is being referred to by the candidate? The argument *must* be clear in order that an examiner can award error carried forward.
- f.iii. This whole sequence of calculations was poorly done. Candidates appear never to have considered the problem of energy loss in the cabling between energy generator and consumer. This ought to be straightforward work for the candidates, but it proved not to be. Solutions as a whole were confused with little clear explanation of what was going on. Candidates were evaluating the wrong quantities without realising it and then misapplying them later in the question. As an example, simply labelling a quantity as “*Power = ...*” is unhelpful. What power is being referred to by the candidate? The argument *must* be clear in order that an examiner can award error carried forward.
- g. Many had rote learnt the first point about laminations in a transformer core: that the eddy currents are reduced. However, a good candidate will realise that the nature of the core must mean that they are never entirely eliminated – complete elimination of the currents was a common and incorrect answer.

---

This question is in **two** parts. **Part 1** is about internal resistance of a cell. **Part 2** is about expansion of a gas.

**Part 1** Internal resistance of a cell

The graph shows the voltage–current ( $V-I$ ) characteristics of a non-ohmic conductor.

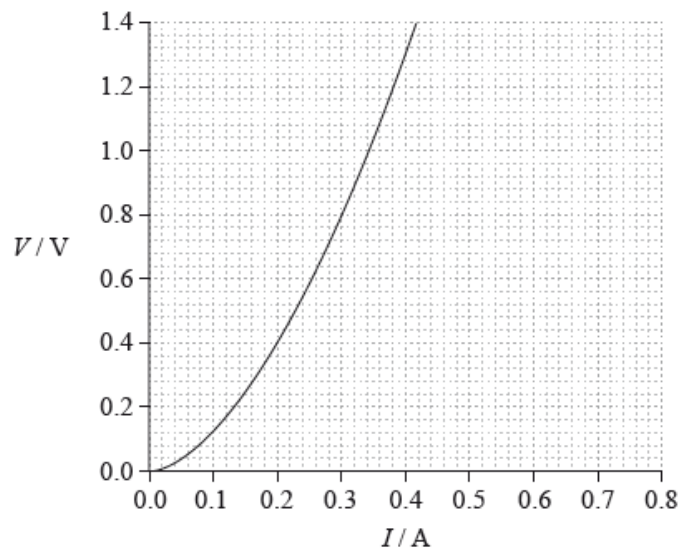

The variable resistor in the circuit in (c) is replaced by this non-ohmic conductor.

**Part 2** Expansion of a gas

b. Outline, with reference to charge carriers, what is meant by the internal resistance of a cell. [3]

d.i. On the graph, sketch the variation of  $V$  with  $I$  for the cell. [2]

d.ii. Using the graph, determine the current in the circuit. [3]

e. The graph shows how the pressure  $P$  of a fixed mass of gas varies with volume  $V$ . The lines show the state of the gas sample during adiabatic expansion and during isothermal expansion. [2]

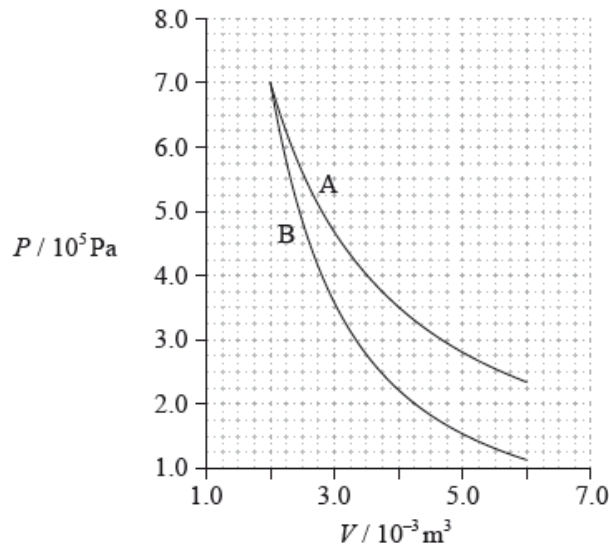

State and explain whether line A or line B represents an adiabatic expansion.

f. Determine the work done during the change represented by line A. [4]

g. Outline, with reference to the first law of thermodynamics, the direction of change in temperature during the adiabatic expansion. [4]

## Markscheme

b. charge carriers/electrons move through cell;

transfer energy to the components of the cell (which is not therefore available to external circuit);

energy dissipated in cell equivalent to dissipation in a resistance;

causes potential difference of cell to be less than its emf;

d.i. straight line of negative gradient; (allow any straight line of negative gradient)

intercept at 1.25 V ( $\pm 0.05$ ) and position/gradient as shown;

Watch for ECF from (c)(iii).

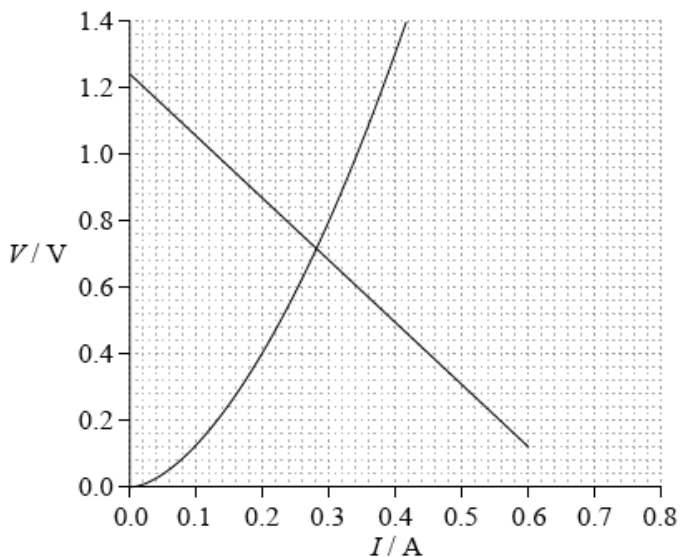

d.ii. uses a point at which lines intersect;

reads correct current value from their own graph;

$0.28\text{A} \pm 0.1\text{A}$ ; (award for correct answer only)

e.  $PV$  is a constant for A / B is a steeper curve / final temperature/pressure lower for B than A;

(hence) B;

f. number of small squares below A =  $180 \pm 20$ ;

area of 1 square = 6.25 J;

adds additional 64 squares below false origin;

answer within the range of 1400 to 1650 J; } (allow ECF for an area that excludes the area below the false origin – giving an answer within the range of 1000 to 1250 J)

Award [2] for a mean  $P$  of  $4.65 \times 10^5 \times \Delta V$  of  $4 \times 10^{-3}$  giving an answer of 1860 (J).

Accept working in large squares (= 16 small squares) using equivalent tolerances.

g. no thermal energy enters or leaves /  $Q = 0$ ;

work done by the gas /  $W$  is positive;

so internal energy decreases /  $\Delta U$  is negative;

temperature is a measure of internal energy and so temperature falls;

## Examiners report

b. This was a 3 mark question about internal resistance, so reasonable detail was expected. Candidates needed to refer to electrons/charge dissipating energy in moving through a cell and the effect on terminal potential difference.

- d.i. Very few correct answers were seen. The equation of the line required is  $V = E - Ir$ . Hence a line of negative gradient ( $-1.9 \Omega$ ) was required with a y intercept of 1.24 V.
- d.ii. If a candidate drew any kind of line, ECF was used when the coordinate of the intersection of the two lines was used to determine a current.
- e. Most candidates were able to identify B as the adiabatic – either by referring to the gradients or lower pressures and temperatures compared to A, or by showing PV was constant for A but not B.
- f. This was a 4 mark question and so candidates needed to give a detailed response. Many stated the 1st law, identified the three symbols and explained the change in each during an adiabatic expansion. Others were far less systematic. Most eventually predicted that temperature would decrease, but lost marks in their explanation.
- g. This was a 4 mark question and so candidates needed to give a detailed response. Many stated the 1st law, identified the three symbols and explained the change in each during an adiabatic expansion. Others were far less systematic. Most eventually predicted that temperature would decrease, but lost marks in their explanation.

A negatively charged thundercloud above the Earth's surface may be modelled by a parallel plate capacitor.

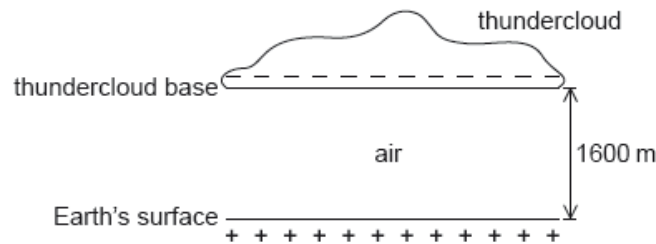

The lower plate of the capacitor is the Earth's surface and the upper plate is the base of the thundercloud.

The following data are available.

Area of thundercloud base	$= 1.2 \times 10^8 \text{ m}^2$
Charge on thundercloud base	$= -25 \text{ C}$
Distance of thundercloud base from Earth's surface	$= 1600 \text{ m}$
Permittivity of air	$= 8.8 \times 10^{-12} \text{ F m}^{-1}$

Lightning takes place when the capacitor discharges through the air between the thundercloud and the Earth's surface. The time constant of the system is 32 ms. A lightning strike lasts for 18 ms.

- a. Show that the capacitance of this arrangement is  $C = 6.6 \times 10^{-7} \text{ F}$ . [1]
- b.i. Calculate in V, the potential difference between the thundercloud and the Earth's surface. [2]
- b.ii. Calculate in J, the energy stored in the system. [2]
- c.i. Show that about  $-11 \text{ C}$  of charge is delivered to the Earth's surface. [3]
- c.ii. Calculate, in A, the average current during the discharge. [1]

d. State **one** assumption that needs to be made so that the Earth-thundercloud system may be modelled by a parallel plate capacitor.

[1]

## Markscheme

a.  $C = \epsilon \frac{A}{d} \Rightarrow 8.8 \times 10^{-12} \times \frac{1.2 \times 10^8}{1600}$

« $C = 6.60 \times 10^{-7} \text{ F}$ »

**[1 mark]**

b.i.  $V = \frac{Q}{C} \Rightarrow \frac{25}{6.6 \times 10^{-7}}$

$V = 3.8 \times 10^7 \text{ «V»}$

Award **[2]** for a bald correct answer

**[2 marks]**

b.ii **ALTERNATIVE 1**

$E = \frac{1}{2} QV \Rightarrow \frac{1}{2} \times 25 \times 3.8 \times 10^7$

$E = 4.7 \times 10^8 \text{ «J»}$

**ALTERNATIVE 2**

$E = \frac{1}{2} CV^2 \Rightarrow \frac{1}{2} \times 6.60 \times 10^{-7} \times (3.8 \times 10^7)^2$

$E = 4.7 \times 10^8 \text{ «J»} / 4.8 \times 10^8 \text{ «J»}$  if rounded value of V used

Award **[2]** for a bald correct answer

Allow ECF from (b)(i)

**[2 marks]**

c.i.  $Q = Q_0 e^{-\frac{t}{\tau}} \Rightarrow 25 \times e^{-\frac{18}{32}}$

$Q = 14.2 \text{ «C»}$

charge delivered =  $Q = 25 - 14.2 = 10.8 \text{ «C»}$

« $\approx -11 \text{ C}$ »

Final answer must be given to at least 3 significant figures

**[3 marks]**

c.ii  $I = \frac{\Delta Q}{\Delta t} = \frac{11}{18 \times 10^{-3}} \approx 610 \text{ «A»}$

Accept an answer in the range 597 – 611 «A»

**[1 mark]**

d. the base of the thundercloud must be parallel to the Earth surface

**OR**

the base of the thundercloud must be flat

OR

the base of the cloud must be very long «compared with the distance from the surface»

[1 mark]

## Examiners report

- a. [N/A]
- b.i. [N/A]
- b.ii. [N/A]
- c.i. [N/A]
- c.ii. [N/A]
- d. [N/A]

This question is in **two** parts. **Part 1** is about fields, electric potential difference and electric circuits. **Part 2** is about thermodynamic cycles.

**Part 1** Fields, electric potential difference and electric circuits

- a. The magnitude of gravitational field strength  $g$  is defined from the equation shown below. [4]

$$g = \frac{F_g}{m}$$

The magnitude of electric field strength  $E$  is defined from the equation shown below.

$$E = \frac{F_E}{q}$$

For each of these defining equations, state the meaning of the symbols

- (i)  $F_g$ .
  - (ii)  $F_E$ .
  - (iii)  $m$ .
  - (iv)  $q$ .
- b. In a simple model of the hydrogen atom, the electron is regarded as being in a circular orbit about the proton. The magnitude of the electric field [3]  
strength at the electron due to the proton is  $E_p$ . The magnitude of the gravitational field strength at the electron due to the proton is  $g_p$ .

Determine the order of magnitude of the ratio shown below.

$$\frac{E_p}{g_p}$$

## Markscheme

- a. (i) the force exerted on a small/test/point mass;

*Do not allow bald "gravitational force".*

- (ii) the force exerted on a small/point/test positive charge;

*To award [1] "positive" is required.*

*Do not allow bald "electric force".*

(iii) the size/magnitude/value of the small/point mass;

Do not accept bald "mass".

(iv) the magnitude/size/value of the small/point/test (positive) charge;

Do not accept bald "charge".

In part (a) only penalize lack of "small/test/point" once, annotate as ECF.

It must be clear that the mass/charge in (iii) & (iv) refer to the object in (i) and (ii).

b.  $E_p = \frac{e}{4\pi\epsilon_0 r^2}$  and  $g_p = \frac{Gm_p}{r^2}$ ; (both needed)

$$\frac{e}{4\pi\epsilon_0 Gm_p} \left( = \frac{9 \times 10^9 \times 1.6 \times 10^{-19}}{6.7 \times 10^{-11} \times 1.7 \times 10^{-27}} \right);$$

$$\approx 10^{28};$$

Award [2 max] if response calculates ratio of force as this is an ECF from the first marking point ( $10^{39}$ ).

Award [3] for solution that correctly evaluates field strengths separately and then divides.

## Examiners report

- a. In this part candidates were completely at a loss and could not state the meanings of the symbols in the definitions of gravitational or electric field strengths. This was a disappointing failure in what was meant to be an easy opener to the whole question.
- b. Following (a) candidates failed widely on this part too. They often had little idea which data to use (mass and charge were frequently confused) and sometimes the meaning of the constants in the equations failed them too. This was compounded by arithmetic errors to make a straightforward calculation very hard for many.

---

This question is in **two** parts. **Part 1** is about electric cells. **Part 2** is about atoms.

### Part 1 Electric cells

Cells used to power small electrical devices contain both conductors and insulators.

Cells also have the property of internal resistance.

### Part 2 Atoms

Photoelectric emission occurs when ultraviolet radiation is incident on the surface of mercury but not when visible light is incident on the metal.

Photoelectric emission occurs when visible light of all wavelengths is incident on caesium.

- a. (i) Distinguish between an insulator and a conductor. [4]
- (ii) Outline what is meant by the internal resistance of a cell.
- c. State what is meant by the photoelectric effect. [1]
- d. (i) Suggest why the work function for caesium is smaller than that of mercury. [4]



(ii) Ultraviolet radiation of wavelength 210 nm is incident on the surface of mercury. The work function for mercury is 4.5 eV. Determine the maximum kinetic energy of the photoelectrons emitted.

- f. An exact determination of the location of the electron in a hydrogen atom is not possible. Outline how this statement is consistent with the Schrödinger model of the hydrogen atom. [3]

## Markscheme

- a. (i) conductor has free electrons/charges that are free to move within/through it / insulator does not have free electrons/charges that are free to move within/ through it;

electrons act as charge carriers;

when a pd acts across a conductor a current exists when charge (carriers) move;

*Do not allow "good/bad conductor/resistor" or reference to conductivity/ resistivity.*

- (ii) some of the power/energy delivered by a cell is used/dissipated in driving current through the cell;

power loss can be equated to  $I^2r$  where  $r$  represents the (internal) resistance of the cell; } (symbols must be defined)

resistance of contents of cell; (do not allow "resistance of cell")

- c. the emission of electrons from a (metal) surface by photons/light/electromagnetic radiation (incident on the surface);

- d. (i) caesium electrons are less firmly bound / mercury requires more energy to release electron; } (allow reverse argument)

*If answer is in terms of threshold frequency, frequency must be linked to energy via  $E = hf$ .*

- (ii) energy of photon =  $\frac{6.63 \times 10^{-34} \times 3 \times 10^8}{2.1 \times 10^{-7}}$  (=  $9.5 \times 10^{-19}$  (J));

convert photon energy to eV, 5.9 (eV) / convert work function to joules  $7.2 \times 10^{-19}$  (J);

so kinetic energy of electron = (photon energy – work function =) 1.4 (eV) **or**  $2.3 \times 10^{-19}$  (J);

*Award [3] for a bald correct answer.*

- f. (Schrödinger model suggests) electron is described by wavefunction;

that gives probability of finding electron at a particular place / probability of finding electrons is proportional to square of (wavefunction) amplitude;

so position of electron is uncertain;

## Examiners report

- a. (i) Superficial answers were common. Candidates continue to ignore the mark allocations for questions and therefore misunderstand the number of independent points they should mention in an answer. Here, most said that conductors contain free electrons (or the reverse for insulators) but did not go on to discuss the role of the free electrons in carrying charge or to relate the current to the existence of an electric field across the conductor. Far too many gave answers of the "conductors conduct well" variety that do not score marks.

(ii) Too often candidates were content to suggest that the internal resistance of a cell is the resistance of the cell contents without discussing the physical implications of this. It was rare to see a consideration of the energy dissipation in the cell or an explanation of the way the power loss is related to a "resistance".

- c. Many candidates were able to give a complete description of the photoelectric effect.

- d. (i) Although the majority were able to relate work function to the physics of the electrons in the metal, some could only respond in terms of the minimum frequency required to produce a photocurrent. This did not generally score marks without some supporting remarks.

(ii) Generally, candidates were able to score at least two marks. Work was marred by power of ten errors and by inability to convert between the electrovolt and the joule. A major reason for errors was that candidates often did not begin with a clear statement of the photoelectric equation followed by substitution in an organised way.

- f. Significant numbers scored two out of three marks. There were some good attempts to link the wavefunction idea to the probability ideas of the theory.

---

A heater in an electric shower has a power of 8.5 kW when connected to a 240 V electrical supply. It is connected to the electrical supply by a copper cable.

The following data are available:

Length of cable = 10 m

Cross-sectional area of cable = 6.0 mm<sup>2</sup>

Resistivity of copper =  $1.7 \times 10^{-8} \Omega \text{ m}$

Calculate the power dissipated in the cable.

## Markscheme

$$\text{power} = \langle 35^2 \times 0.028 \rangle = 34 \langle \text{W} \rangle$$

*Allow 35 – 36 W if unrounded figures for R or I are used.*

*Allow ECF from (a)(i) and (a)(ii).*

## Examiners report

[N/A]

---

A beam of electrons  $e^-$  enters a uniform electric field between parallel conducting plates RS. RS are connected to a direct current (dc) power supply. A uniform magnetic field B is directed into the plane of the page and is perpendicular to the direction of motion of the electrons.

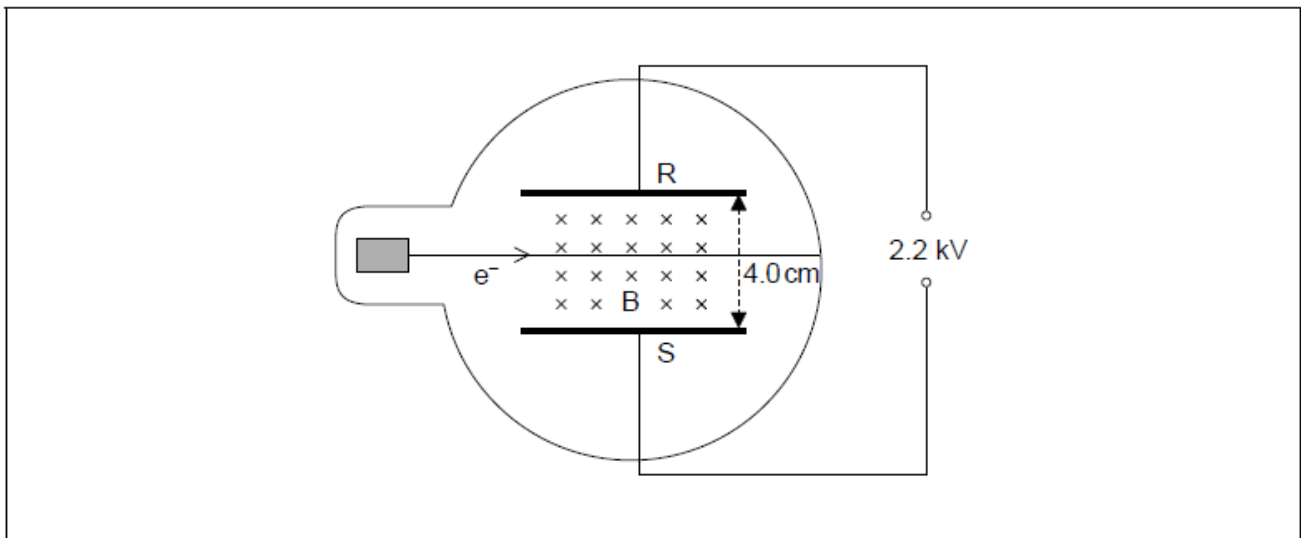

The magnetic field is adjusted until the electron beam is **undeflected** as shown.

a. Identify, on the diagram, the direction of the electric field between the plates. [1]

b. The following data are available. [2]

Separation of the plates RS	= 4.0 cm
Potential difference between the plates	= 2.2 kV
Velocity of the electrons	= $5.0 \times 10^5 \text{ m s}^{-1}$

Determine the strength of the magnetic field B.

c. The velocity of the electrons is now increased. Explain the effect that this will have on the path of the electron beam. [2]

## Markscheme

a. direction indicated downwards, perpendicular to plates

*Arrows must be between plates but allow edge effects if shown. Only one arrow is required.*

b.  $E = \frac{V}{d} = 55\,000 \text{ «Vm}^{-1}\text{»}$

$B = \frac{55\,000}{5 \times 10^5} \Rightarrow 0.11 \text{ «T»}$

*ECF applies from MP1 to MP2 due to math error.*

*Award [2] for a bald correct answer.*

c. **ALTERNATIVE 1**

magnetic force increases

**OR**

magnetic force becomes greater than electric force

electron beam deflects “downwards” / towards S

**OR**

path of beam is downwards

**ALTERNATIVE 2**

when  $v$  increases, the  $B$  required to maintain horizontal path decreases

«but  $B$  is constant» so path of beam is downwards

Do **not** apply an ecf from (a).

Award **[1 max]** if answer states that magnetic force decreases and therefore path is upwards.

Ignore any statement about shape of path

Do not allow "path deviates in direction of magnetic force" without qualification.

## Examiners report

- a. [N/A]
- b. [N/A]
- c. [N/A]

Hydrogen atoms in an ultraviolet (UV) lamp make transitions from the first excited state to the ground state. Photons are emitted and are incident on a photoelectric surface as shown.

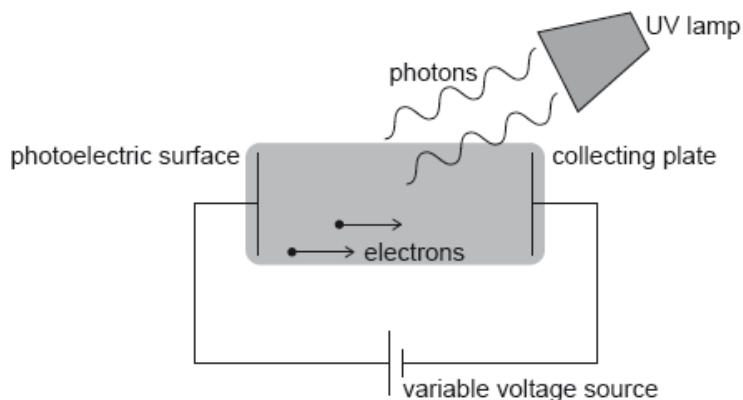

The photons cause the emission of electrons from the photoelectric surface. The work function of the photoelectric surface is 5.1 eV.

The electric potential of the photoelectric surface is 0 V. The variable voltage is adjusted so that the collecting plate is at -1.2 V.

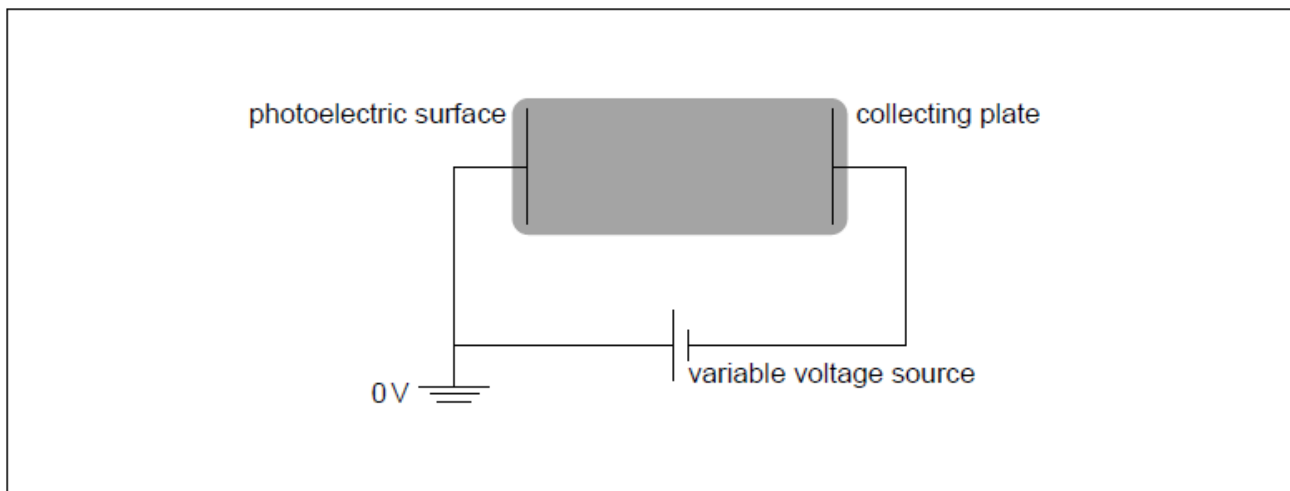

a. Show that the energy of photons from the UV lamp is about 10 eV.

[2]

b.i. Calculate, in J, the maximum kinetic energy of the emitted electrons.

[2]

b.ii. Suggest, with reference to conservation of energy, how the variable voltage source can be used to stop all emitted electrons from reaching the collecting plate. [2]

b.iii. The variable voltage can be adjusted so that no electrons reach the collecting plate. Write down the minimum value of the voltage for which no electrons reach the collecting plate. [1]

c.i. On the diagram, draw and label the equipotential lines at  $-0.4\text{ V}$  and  $-0.8\text{ V}$ . [2]

c.ii. An electron is emitted from the photoelectric surface with kinetic energy  $2.1\text{ eV}$ . Calculate the speed of the electron at the collecting plate. [2]

## Markscheme

a.  $E_1 = -13.6\text{ «eV»}$   $E_2 = -\frac{13.6}{4} = -3.4\text{ «eV»}$

energy of photon is difference  $E_2 - E_1 = 10.2\text{ «}\approx 10\text{ eV»}$

*Must see at least 10.2 eV.*

**[2 marks]**

b.i.  $10 - 5.1 = 4.9\text{ «eV»}$

$4.9 \times 1.6 \times 10^{-19} = 7.8 \times 10^{-19}\text{ «J»}$

*Allow 5.1 if 10.2 is used to give  $8.2 \times 10^{-19}\text{ «J»}$ .*

b.ii. EPE produced by battery

exceeds maximum KE of electrons / electrons don't have enough KE

*For first mark, accept explanation in terms of electric potential energy difference of electrons between surface and plate.*

**[2 marks]**

b.iii.  $4.9\text{ «V»}$

*Allow 5.1 if 10.2 is used in (b)(i).*

*Ignore sign on answer.*

**[1 mark]**

c.i. two equally spaced vertical lines (judge by eye) at approximately  $1/3$  and  $2/3$

labelled correctly

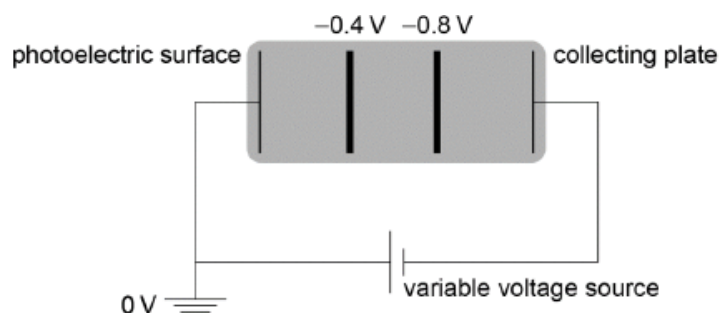

[2 marks]

c.ii.kinetic energy at collecting plate = 0.9 «eV»

$$\text{speed} = \sqrt{\frac{2 \times 0.9 \times 1.6 \times 10^{-19}}{9.11 \times 10^{-31}}} = 5.6 \times 10^5 \text{ «ms}^{-1}\text{»}$$

Allow ECF from MP1

[2 marks]

## Examiners report

- a. [N/A]
- b.i. [N/A]
- b.ii. [N/A]
- b.iii. [N/A]
- c.i. [N/A]
- c.ii. [N/A]

A non-uniform electric field, with field lines as shown, exists in a region where there is no gravitational field. X is a point in the electric field. The field lines and X lie in the plane of the paper.

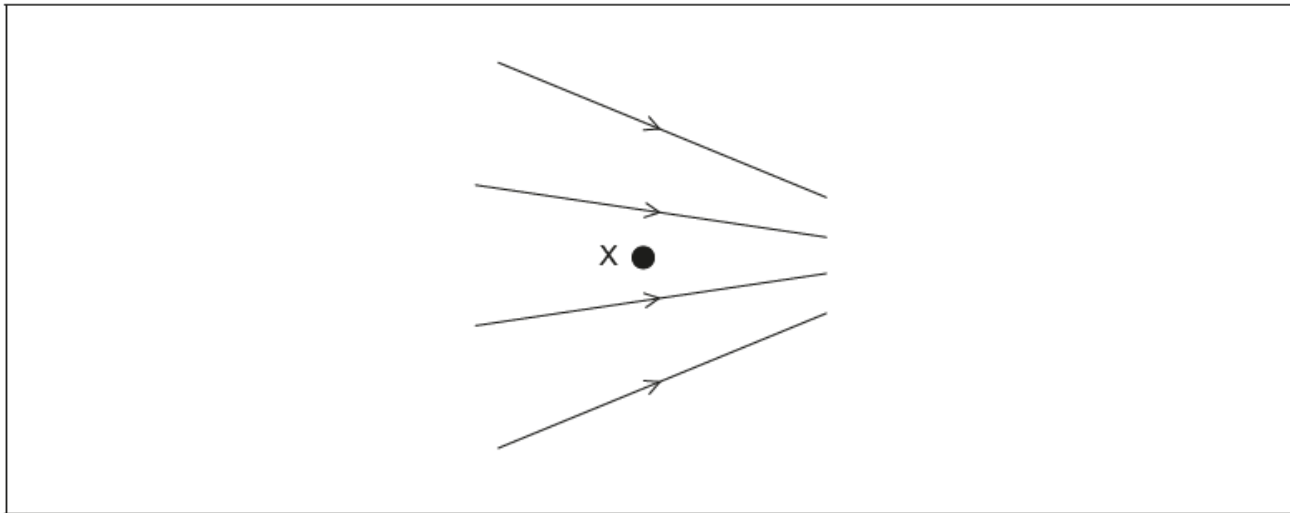

- a. Outline what is meant by electric field strength. [2]
- b. An electron is placed at X and released from rest. Draw, on the diagram, the direction of the force acting on the electron due to the field. [1]
- c. The electron is replaced by a proton which is also released from rest at X. Compare, without calculation, the motion of the electron with the motion of the proton after release. You may assume that no frictional forces act on the electron or the proton. [4]

## Markscheme

- a. force per unit charge  
acting on a small/test positive charge

b. horizontally to the left

*Arrow does not need to touch X*

c. proton moves to the right/they move in opposite directions

force on each is initially the same

proton accelerates less than electron initially «because mass is greater»

field is stronger on right than left «as lines closer»

proton acceleration increases «as it is moving into stronger field»

**OR**

electron acceleration decreases «as it is moving into weaker field»

*Allow ECF from (b)*

*Accept converse argument for electron*

## Examiners report

a. [N/A]

b. [N/A]

c. [N/A]

A cable consisting of many copper wires is used to transfer electrical energy from an alternating current (ac) generator to an electrical load. The copper wires are protected by an insulator.

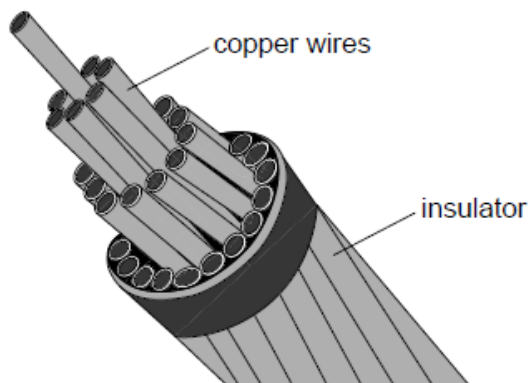

The cable consists of 32 copper wires each of length 35 km. Each wire has a resistance of  $64 \Omega$ . The cable is connected to the ac generator which has an output power of 110 MW when the peak potential difference is 150 kV. The resistivity of copper is  $1.7 \times 10^{-8} \Omega \text{ m}$ .

output power = 110 MW

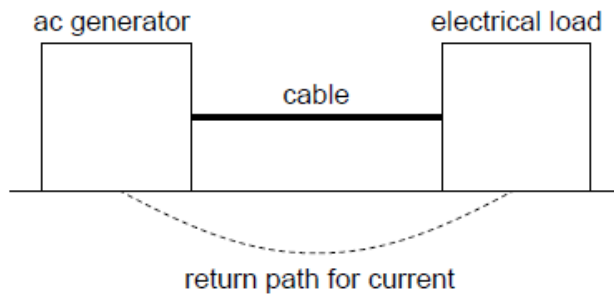

To ensure that the power supply cannot be interrupted, two identical cables are connected in parallel.

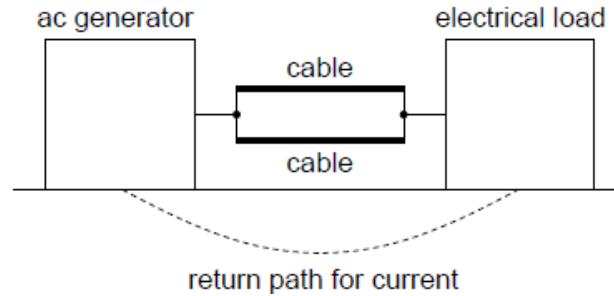

The energy output of the ac generator is at a much lower voltage than the 150 kV used for transmission. A step-up transformer is used between the generator and the cables.

- b.i. Calculate the radius of each **wire**. [2]
- b.ii. Calculate the peak current in the **cable**. [1]
- b.iii. Determine the power dissipated in the cable per unit length. [3]
- c. Calculate the root mean square (rms) current in each cable. [1]
- d. The two cables in part (c) are suspended a constant distance apart. Explain how the magnetic forces acting between the cables vary during the course of one cycle of the alternating current (ac). [2]
- e.i. Suggest the advantage of using a step-up transformer in this way. [2]
- e.ii. The use of alternating current (ac) in a transformer gives rise to energy losses. State how eddy current loss is minimized in the transformer. [1]

## Markscheme

$$\text{b.i. area} = \frac{1.7 \times 10^{-3} \times 35 \times 10^3}{64} \llcorner = 9.3 \times 10^{-6} \text{ m}^2 \llcorner$$

$$\text{radius} = \llcorner \sqrt{\frac{9.3 \times 10^{-6}}{\pi}} \Rightarrow 0.00172 \text{ m} \llcorner$$

$$\text{b.ii. } I_{\text{peak}} \llcorner = \frac{P_{\text{peak}}}{V_{\text{peak}}} \llcorner = 730 \llcorner \text{ A} \llcorner$$

$$\text{b.iii. resistance of cable identified as } \llcorner \frac{64}{32} \Rightarrow 2 \Omega \llcorner$$



$\frac{\text{a power}}{35000}$  seen in solution

plausible answer calculated using  $\frac{2I^2}{35000}$  «plausible if in range  $10 \text{ W m}^{-1}$  to  $150 \text{ W m}^{-1}$  when quoted answers in (b)(ii) used»  $31 \text{ «W m}^{-1}\text{»}$

Allow **[3]** for a solution where the resistance per unit metre is calculated using resistivity and answer to (a) (resistance per unit length of cable =  $5.7 \times 10^{-5} \text{ m}$ )

Award **[2 max]** if  $64 \Omega$  used for resistance (answer  $\times 32$ ).

An approach from  $\frac{V^2}{R}$  or  $VI$  using  $150 \text{ kV}$  is incorrect (award **[0]**), however allow this approach if the pd across the cable has been calculated (pd dropped across cable is  $1.47 \text{ kV}$ ).

c. « $\frac{\text{response to (b)(ii)}}{2\sqrt{2}}$ » =  $260 \text{ «A»}$

d. wires/cable attract whenever current is in same direction

charge flow/current direction in both wires is always same «but reverses every half cycle»

force varies from 0 to maximum

force is a maximum twice in each cycle

Award **[1 max]** if response suggests that there is repulsion between cables at any stage in cycle.

e.i. higher voltage gives lower current

«energy losses depend on current» hence thermal/heating/power losses reduced

e.ii. laminated core

Do not allow “wires are laminated”.

## Examiners report

b.i. [N/A]

b.ii. [N/A]

b.iii. [N/A]

c. [N/A]

d. [N/A]

e.i. [N/A]

e.ii. [N/A]

There is a proposal to power a space satellite X as it orbits the Earth. In this model, X is connected by an electronically-conducting cable to another smaller satellite Y.

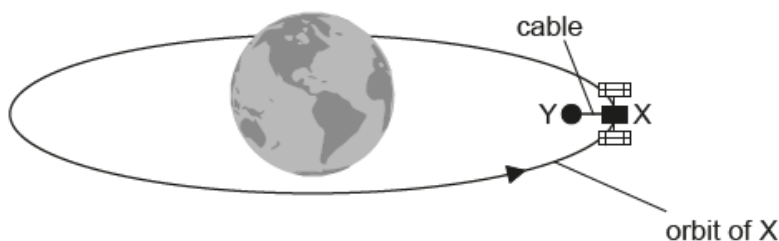

not to scale

Satellite Y orbits closer to the centre of Earth than satellite X. Outline why

The cable acts as a spring. Satellite Y has a mass  $m$  of  $3.5 \times 10^2$  kg. Under certain circumstances, satellite Y will perform simple harmonic motion (SHM) with a period  $T$  of 5.2 s.

a. Satellite X orbits 6600 km from the centre of the Earth. [2]

Mass of the Earth =  $6.0 \times 10^{24}$  kg

Show that the orbital speed of satellite X is about  $8 \text{ km s}^{-1}$ .

b.i. the orbital times for X and Y are different. [1]

b.ii. satellite Y requires a propulsion system. [2]

c. The cable between the satellites cuts the magnetic field lines of the Earth at right angles. [3]

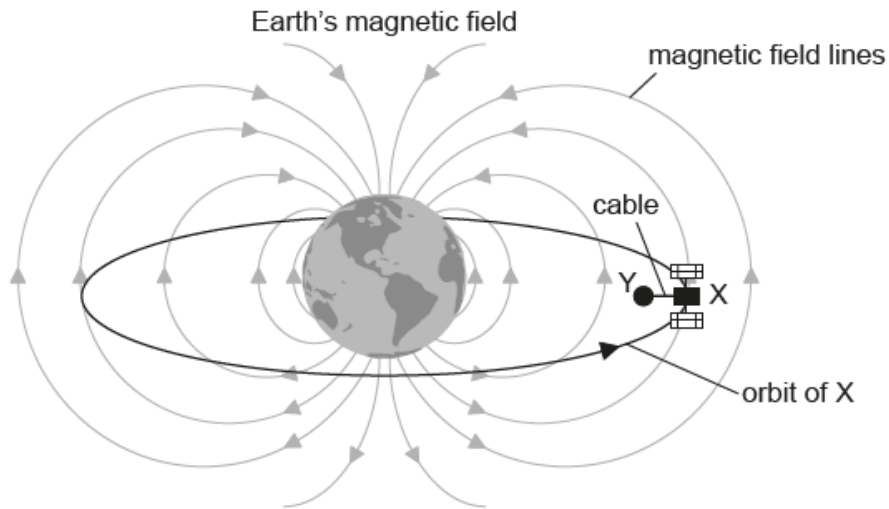

not to scale

Explain why satellite X becomes positively charged.

d. Satellite X must release ions into the space between the satellites. Explain why the current in the cable will become zero unless there is a method for transferring charge from X to Y. [3]

e. The magnetic field strength of the Earth is  $31 \mu\text{T}$  at the orbital radius of the satellites. The cable is 15 km in length. Calculate the emf induced in the cable. [2]

f.i. Estimate the value of  $k$  in the following expression. [3]

$$T = 2\pi \sqrt{\frac{m}{k}}$$

Give an appropriate unit for your answer. Ignore the mass of the cable and any oscillation of satellite X.

f.ii. Describe the energy changes in the satellite Y-cable system during one cycle of the oscillation. [2]

## Markscheme

a. « $v = \sqrt{\frac{GM_E}{r}}$ » =  $\sqrt{\frac{6.67 \times 10^{-11} \times 6.0 \times 10^{24}}{6600 \times 10^3}}$

7800 « $\text{m s}^{-1}$ »

Full substitution required

Must see 2+ significant figures.

b.i. Y has smaller orbit/orbital speed is greater so time period is less

Allow answer from appropriate equation

Allow converse argument for X

b.ii. to stop Y from getting ahead

to remain stationary with respect to X

otherwise will add tension to cable/damage satellite/pull X out of its orbit

c. cable is a conductor and contains electrons

electrons/charges experience a force when moving in a magnetic field

use of a suitable hand rule to show that satellite Y becomes negative «so X becomes positive»

**Alternative 2**

cable is a conductor

so current will flow by induction flow when it moves through a B field

use of a suitable hand rule to show current to right so «X becomes positive»

Marks should be awarded from either one alternative or the other.

Do not allow discussion of positive charges moving towards X

d. electrons would build up at satellite Y/positive charge at X

preventing further charge flow

by electrostatic repulsion

unless a complete circuit exists

e. « $\mathcal{E} = Blv \Rightarrow 31 \times 10^{-6} \times 7990 \times 15000$

3600 «V»

Allow 3700 «V» from  $v = 8000 \text{ m s}^{-1}$ .

f.i. use of  $k = \frac{4\pi^2 m}{T^2} \Rightarrow \frac{4 \times \pi^2 \times 350}{5.2^2}$

510

$\text{N m}^{-1}$  or  $\text{kg s}^{-2}$

Allow MP1 and MP2 for a bald correct answer

Allow 500

Allow N/m etc.

f.ii.  $E_p$  in the cable/system transfers to  $E_k$  of Y

and back again twice in each cycle

Exclusive use of gravitational potential energy negates MP1

## Examiners report

a. [N/A]

b.i. [N/A]

[N/A]

- b.ii. [N/A]
- d. [N/A]
- e. [N/A]
- f.i. [N/A]
- f.ii. [N/A]

a. Two cells of negligible internal resistance are connected in a circuit.

[2]

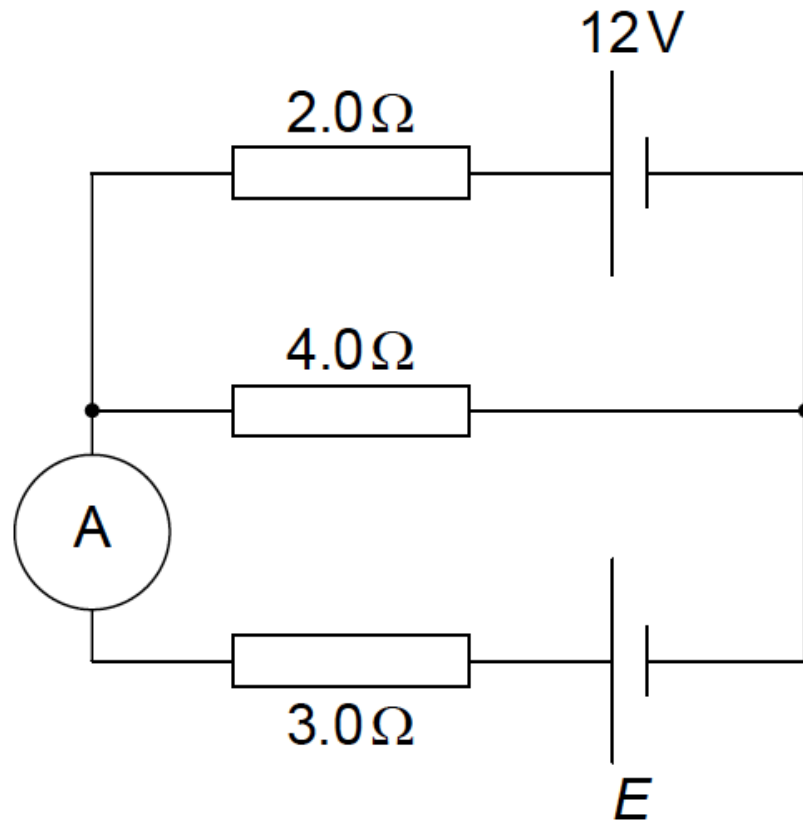

The top cell has electromotive force (emf) 12V. The emf of the lower cell is unknown. The ideal ammeter reads zero current. Calculate the emf  $E$  of the lower cell.

b. The diagram shows charge carriers moving with speed  $v$  in a metallic conductor of width  $L$ . The conductor is exposed to a uniform magnetic field  $B$  that is directed into the page.

[3]

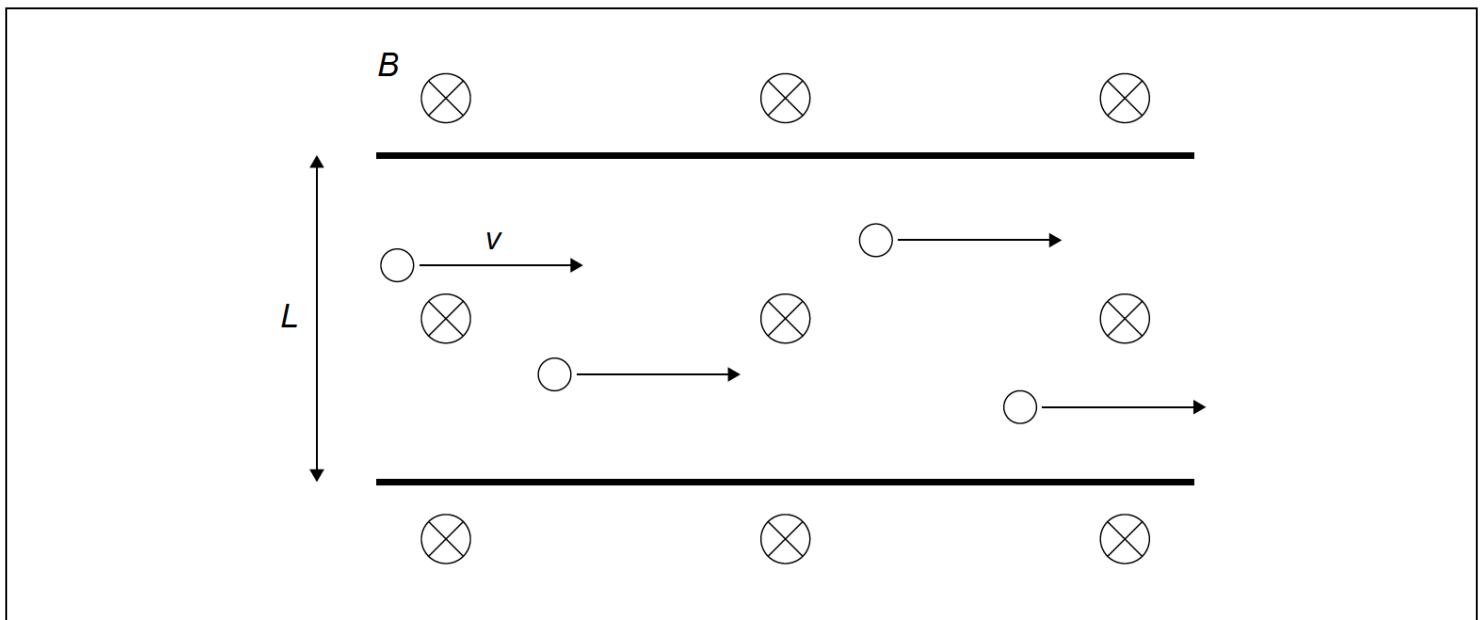

(i) Show that the potential difference  $V$  that is established across the conductor is given by  $V = vBL$ .

(ii) On the diagram, label the part of the conductor where negative charge accumulates.

## Markscheme

### a. ALTERNATIVE 1

correct application of Kirchoff to at least one loop

$$E = \ll 4.0 \times 2.0 \Rightarrow 8.0V$$

#### FOR EXAMPLE

$12 = 2.0I_1 + 4.0I_2$  for top loop with loop anticlockwise

«but  $I_2 = I_1$  as  $I_3 = 0$ »

« $E \Rightarrow 8.0 V$ »

#### ALTERNATIVE 2

«recognition that situation is simple potential divider arrangement»

$$\text{pd across } 4\Omega \text{ resistor} = \frac{12 \times 4}{(2+4)}$$

$$= 8V$$

Award **[0]** for any answer that begins with the treatment as parallel resistors.

### b. (i)

#### ALTERNATIVE 1

equating electric to magnetic force  $qE = qvB$

$$\text{substituting } E = \frac{V}{L}$$

«to get given result»

#### ALTERNATIVE 2

$$V = \frac{\text{work done}}{Q} \text{ AND work done} = \text{force} \times \text{distance}$$

$$\text{work done} = qv = Bqv \times L$$

«to get given result»

### (ii)

some mark indicating lower surface of conductor

**OR**

indication that **positive** charge accumulates at top of conductor

Do not allow negative or positive at top **and** bottom.

## Examiners report

- a. [N/A]
- b. [N/A]

This question is about a thermistor circuit.

The circuit shows a negative temperature coefficient (NTC) thermistor X and a  $100\text{ k}\Omega$  fixed resistor R connected across a battery.

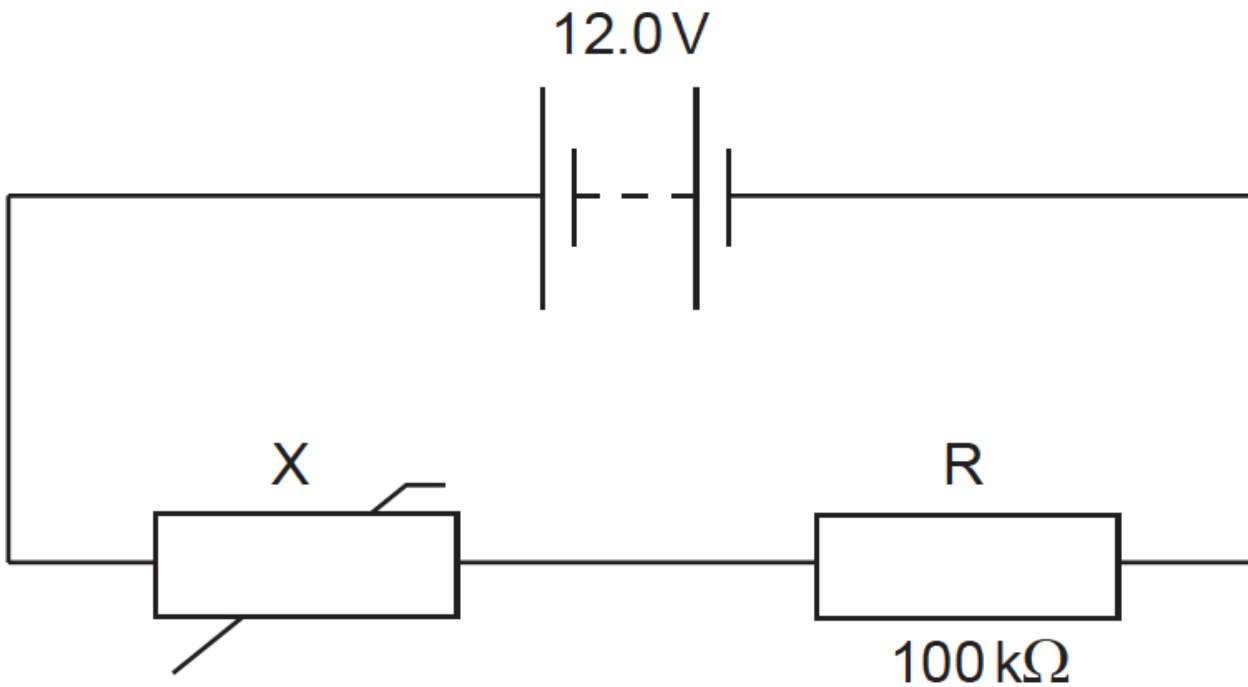

The battery has an electromotive force (emf) of  $12.0\text{ V}$  and negligible internal resistance.

a. Define *electromotive force (emf)*.

[1]

b. The graph below shows the variation with temperature  $T$  of the resistance  $R_X$  of the thermistor.

[7]

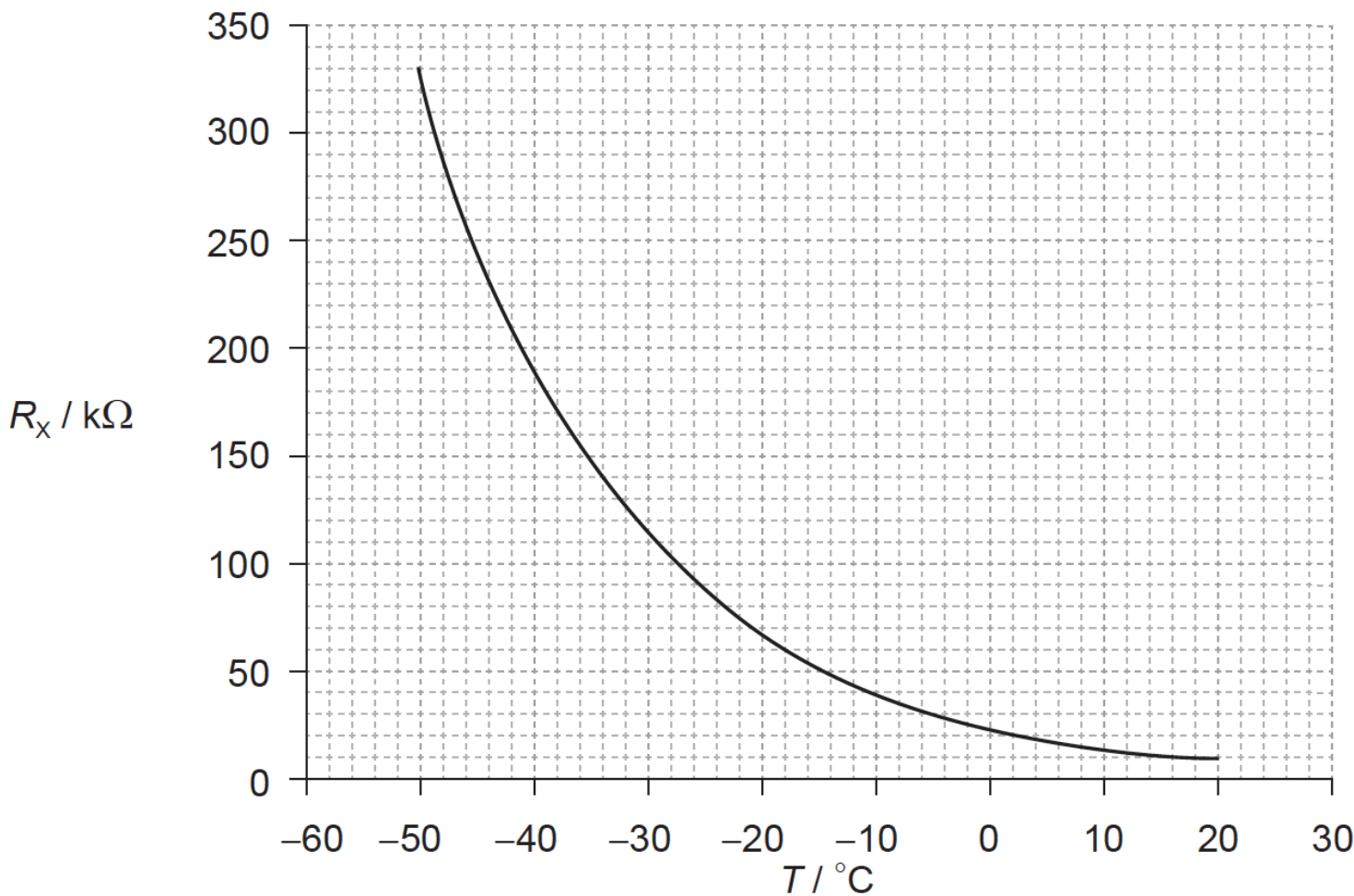

- (i) Determine the temperature of X when the potential difference across R is 4.5 V.
- (ii) State the range of temperatures for which the change in the resistance of the thermistor is most sensitive to changes in temperature.
- (iii) State and explain the effect of a decrease in temperature on the ratio  $\frac{\text{voltage across X}}{\text{voltage across R}}$ .

## Markscheme

- a. the work done per unit charge in moving a quantity of charge completely around a circuit / the power delivered per unit current / work done per unit charge made available by a source;
- b. (i)  $V_X = 7.5 \text{ (V)}$ ;  
 $I \left( = \frac{4.5}{100 \times 10^3} \right) = 4.5 \times 10^{-5} \text{ A}$  **or**  $\frac{V_X}{V_R} = \frac{R_X}{R_R}$ ;  
 $R_X \left( = \frac{7.5}{4.5 \times 10^{-5}} \right) = 1.67 \times 10^5 \Omega$  **or**  $R_X \left( = \frac{7.5}{4.5} \times 100 \times 10^3 \right) = 1.67 \times 10^5 \Omega$ ;  
 $T = -37$  **or**  $-38 \text{ } ^\circ\text{C}$
- (ii)  $-50$  to (up to)  $-30 \text{ } ^\circ\text{C}$  / at low temperatures;
- (iii) as the temperature decreases  $R_X$  increases; same current through  $R$  and  $X$  so the ratio increases **or**  $V_X$  increases and  $V_R$  decreases so the ratio increases;

## Examiners report

- a. [N/A]
- b. [N/A]

This question is in **two** parts. **Part 1** is about the properties of tungsten. **Part 2** is about the properties of a gas.

**Part 1** Properties of tungsten

An isolated nucleus of an atom of the metal tungsten contains 74 protons.

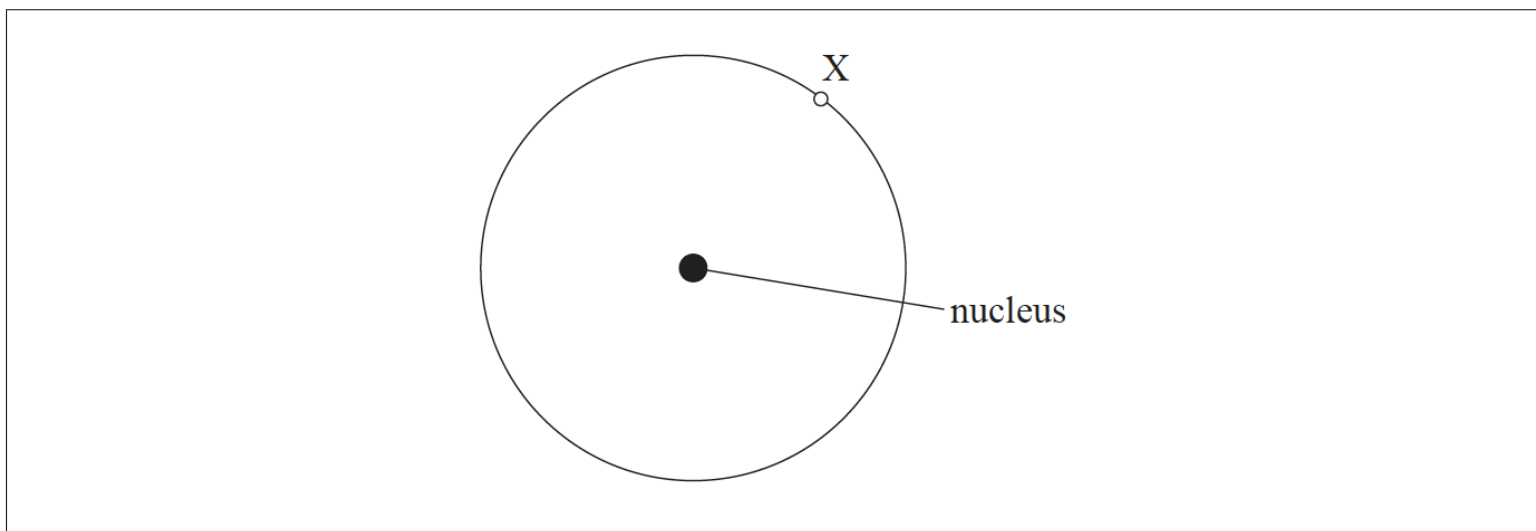

Point X is 140 pm from the nucleus.

- a. (i) On the diagram above, draw an arrow to show the direction of the electric field at point X. [3]
- (ii) Assuming the nucleus acts as a point charge, determine the magnitude of the electric field strength at point X.
- d. (d) The diagram shows part of a potential divider circuit used to measure the current-potential difference ( $I$ - $V$ ) characteristic of the bulb. [4]

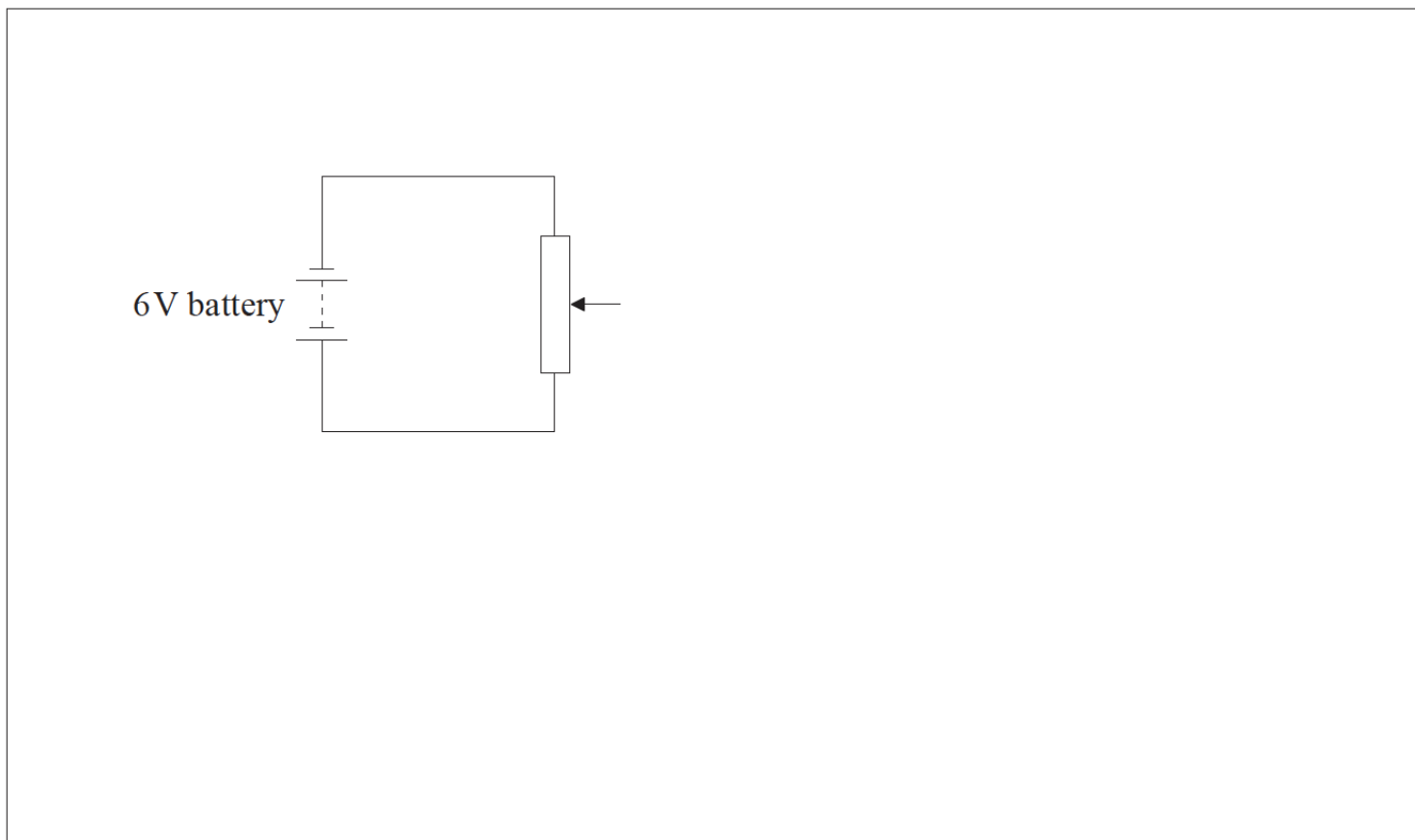

- (i) Draw the complete circuit showing the correct position of the bulb, ammeter and voltmeter.



(ii) On the axes provided, sketch a graph to show how the current in the bulb varies with the potential difference.

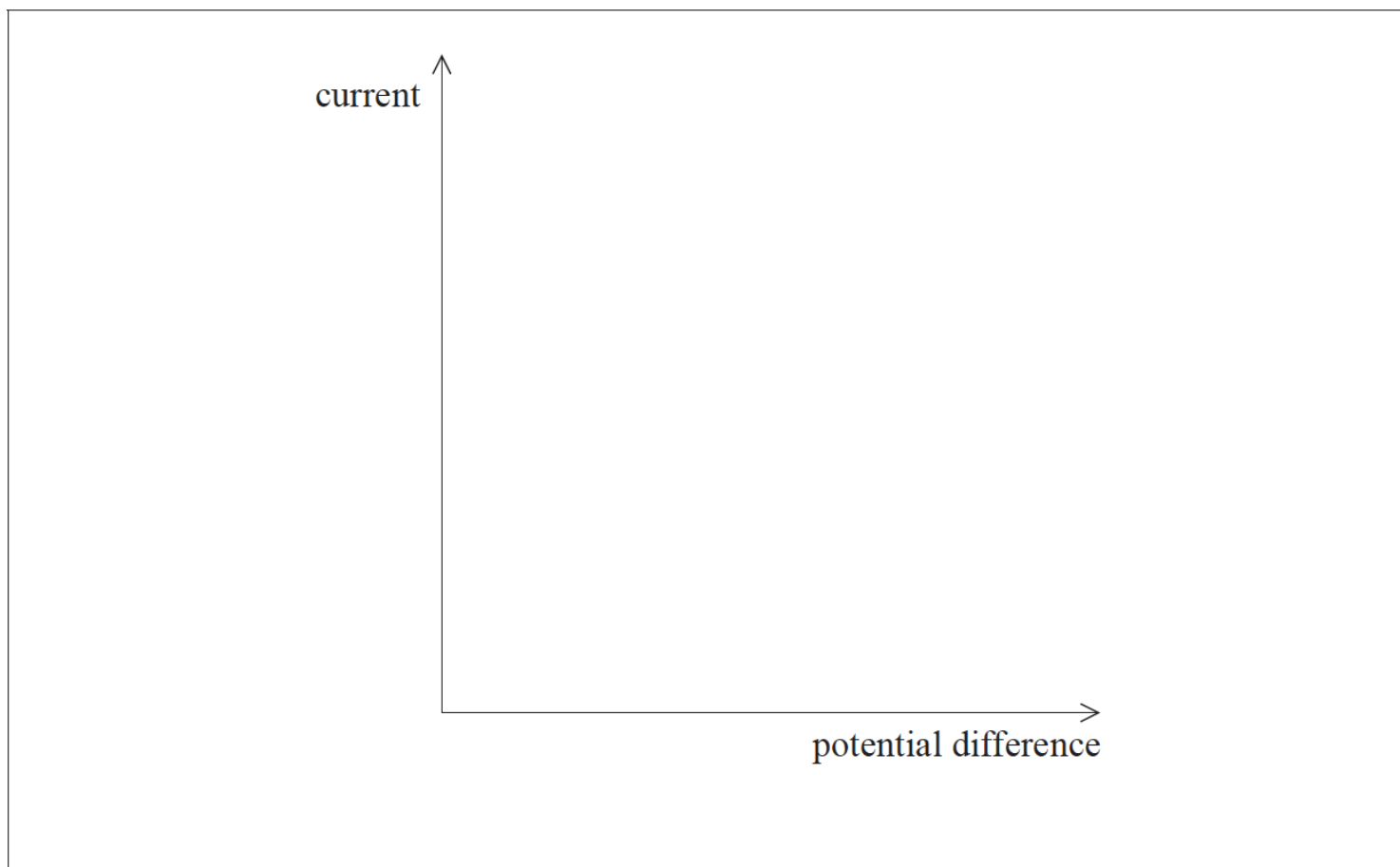

e. A student sets up a different circuit to measure the  $I$ - $V$  graph. The cell has an emf of 6.0 V and negligible internal resistance. The variable resistor has a minimum resistance of zero and a maximum resistance of 5.0  $\Omega$ .

[3]

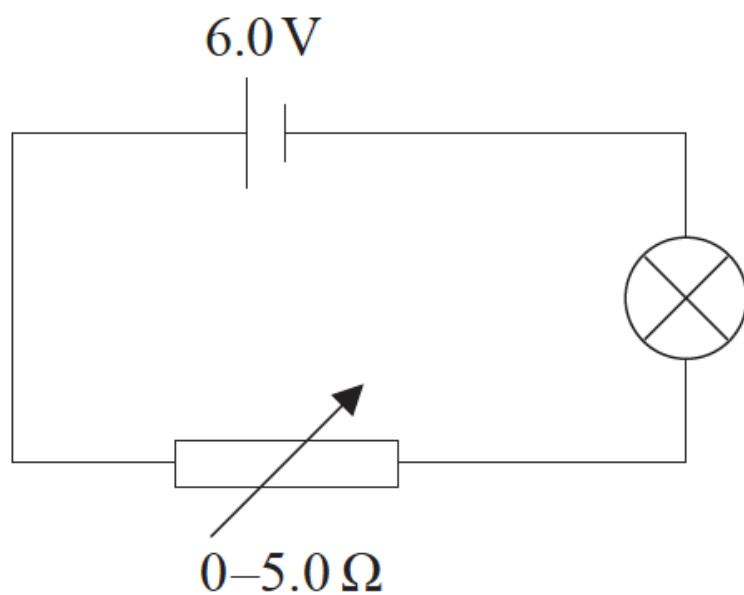

Explain, with a calculation, why this circuit will not allow for a full range of potential difference from 0 V to 6 V across the bulb. Assume that the resistance of the lamp remains constant at a value of 2.4  $\Omega$ .

## Markscheme

a. (i) arrow pointing away from nucleus;

$$(ii) E = \frac{74 \times 1.6 \times 10^{-19}}{4\pi \times 8.85 \times 10^{-12} \times [1.4 \times 10^{-10}]^2};$$

$$5.4 \times 10^{12} \text{Vm}^{-1} \text{ or } \text{NC}^{-1};$$

Award **[2]** for a bald correct answer.

d. (i) lamp connected so that pd can be varied;

ammeter in series with lamp and voltmeter in parallel with lamp; *(both needed)*

Award **[0]** if lamp cannot light.

(ii) through origin;

correct shape;

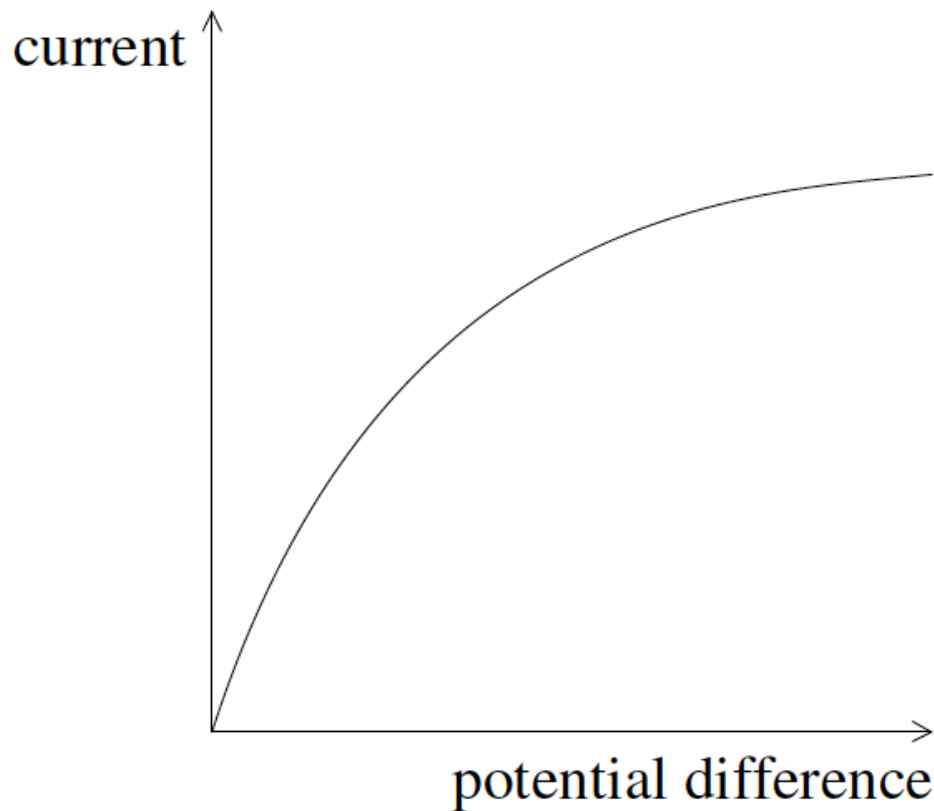

e. minimum pd across bulb is when  $R=5.0\Omega$  ;

$$\text{pd across bulb} = 6.0 \times \frac{2.4}{7.4}$$

$$= 1.9 \text{ (V) or } 2.0 \text{ (V)};$$

so range  $-1.9-6.0\text{V}$  or  $0\text{V}$  across lamp cannot be obtained;

## Examiners report

a. [N/A]

d. [N/A]

e. [N/A]

### Part 1 Electrical and magnetic characteristics of a loudspeaker

The diagram shows the main features of a loudspeaker L. A current-carrying coil is positioned within the magnetic field provided by a permanent magnet. The diagram also shows the directions of the magnetic field and of the current in the coil at a particular instant. The dust cap D prevents dust from blocking the gap between the cardboard tube and the south pole of the magnet.

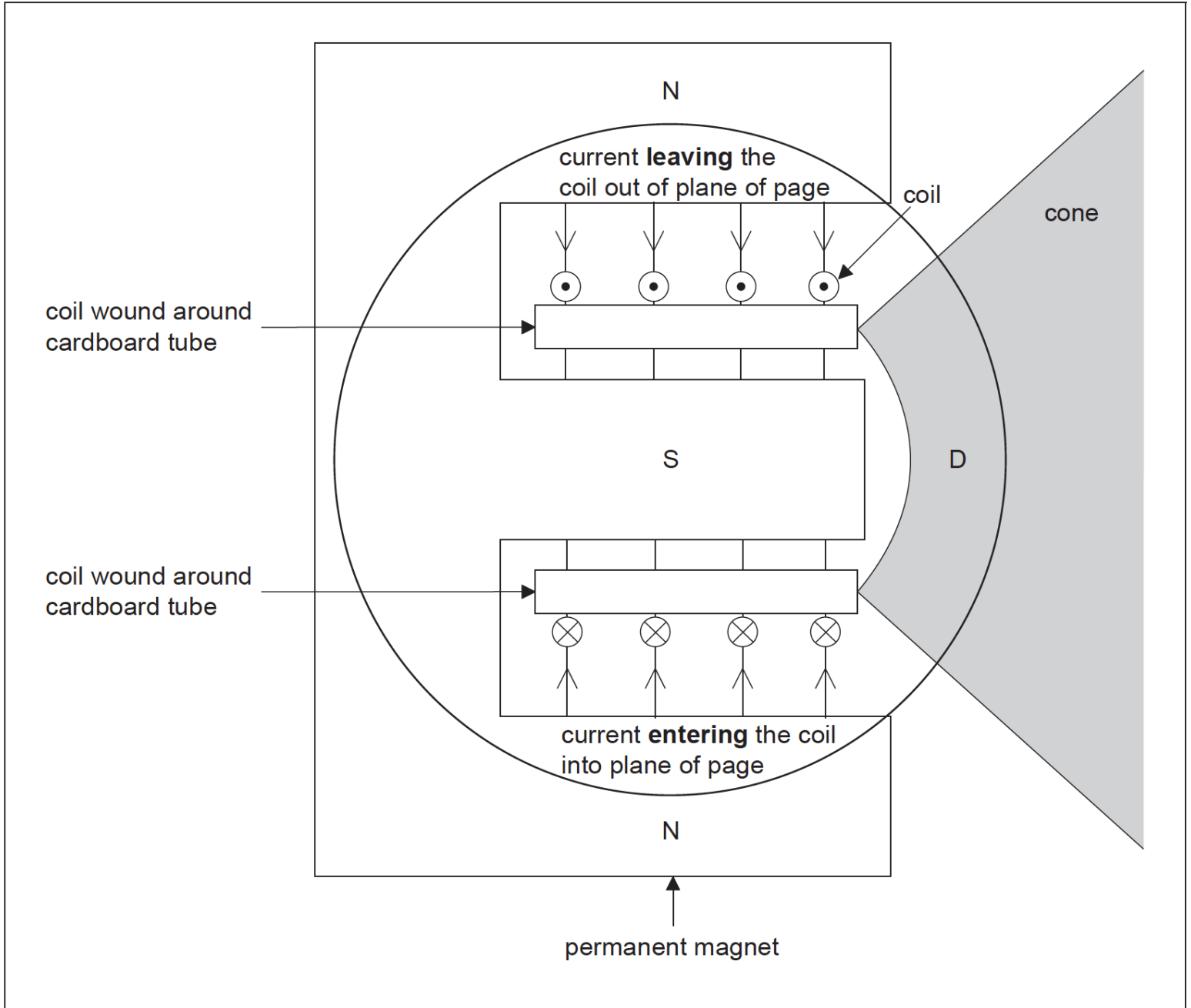

The coil consists of 150 turns, each of average diameter 2.5 cm. The magnetic field of the permanent magnet has strength 0.40 mT. The peak current in the coil is 0.45 mA.

- Identify, **on the diagram**, the direction of the force on the coil with the current directions shown. [2]
- Calculate the maximum magnetic force acting on the coil. [3]
- Explain, with reference to electromagnetic induction, the effect of the motion of the coil on the current. [3]

## Markscheme

a. force in correct location on diagram, *ie* arrow on coil;

force direction to the right;

*Award [1 max] if any other forces drawn.*

b.  $L = (2\pi rN) = 2 \times \pi \times 1.25 \times 10^{-2} \times 150 = (11.8) \text{ m};$

$$F = (BIL) = 0.40 \times 10^{-3} \times 0.45 \times 10^{-3} \times 11.8;$$
$$= 2.1 \times 10^{-6} \text{ N} / 2.1 \mu\text{N}$$

d. (as the coil moves the) conductor cuts the magnetic field / there is a change in flux linkage;

induces an emf across the coil / a current through the coil;

opposes the driving potential difference;

reduces the (net) current;

## Examiners report

a. [N/A]

b. [N/A]

d. [N/A]

---

This question is in two parts. **Part 1** is about current electricity. **Part 2** is about atoms.

### Part 1 Current electricity

### Part 2 Atoms

a. A  $24\Omega$  resistor is made from a conducting wire. [8]

(i) The diameter of the wire is 0.30 mm and the wire has a resistivity of  $1.7 \times 10^{-8} \Omega \text{ m}$ . Calculate the length of the wire.

(ii) A potential difference of 12V is applied between the ends of the wire. Calculate the acceleration of a free electron in the wire.

(iii) Suggest why the average speed of the free electron does not keep increasing even though it is being accelerated.

b. An electric circuit consists of a supply connected to a  $24\Omega$  resistor in parallel with a variable resistor of resistance  $R$ . The supply has an emf of 12V and an internal resistance of  $11\Omega$ . [7]

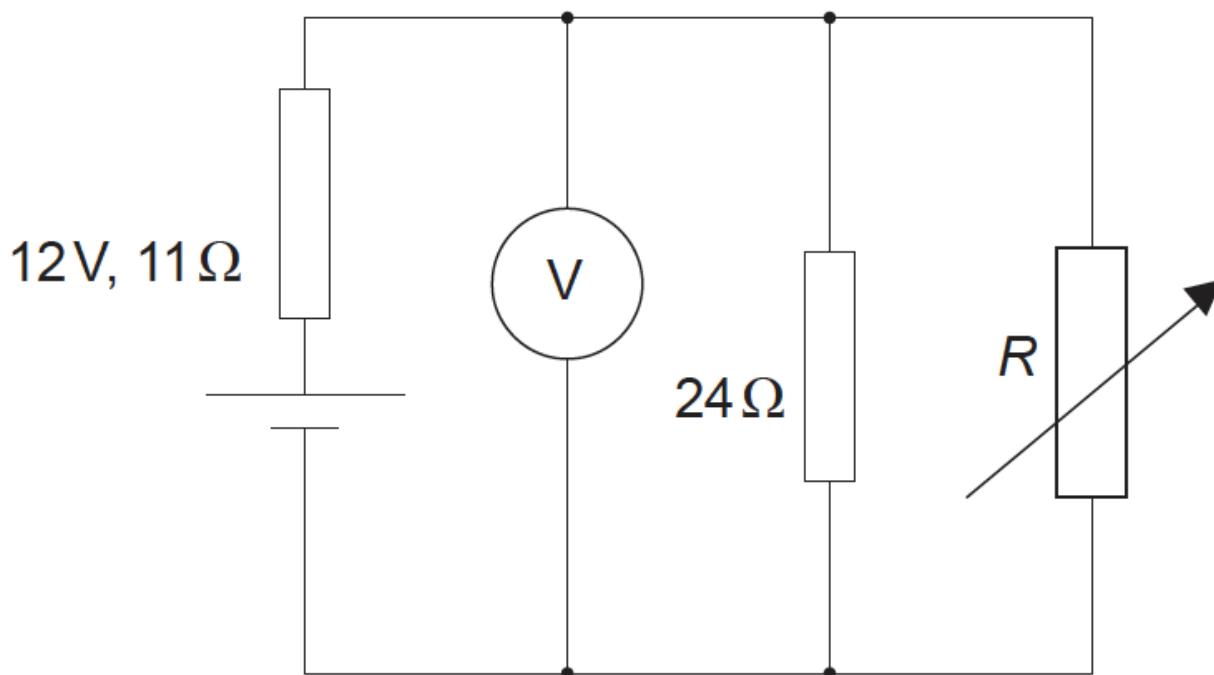

Power supplies deliver maximum power to an external circuit when the resistance of the external circuit equals the internal resistance of the power supply.

- (i) Determine the value of  $R$  for this circuit at which maximum power is delivered to the external circuit.
- (ii) Calculate the reading on the voltmeter for the value of  $R$  you determined in (b)(i).
- (iii) Calculate the power dissipated in the  $24\Omega$  resistor when the maximum power is being delivered to the external circuit.

c. State what is meant by the wavefunction of an electron.

[1]

d. An electron is confined in a length of  $2.0 \times 10^{-10}$  m.

[9]

- (i) Determine the uncertainty in the momentum of the electron.
- (ii) The electron has a momentum of  $2.0 \times 10^{-23}$ Ns. Determine the de Broglie wavelength of the electron.
- (iii) On the axes, sketch the variation of the wavefunction  $\Psi$  of the electron in (d)(ii) with distance  $x$ . You may assume that  $\Psi = 0$  when  $x = 0$ .

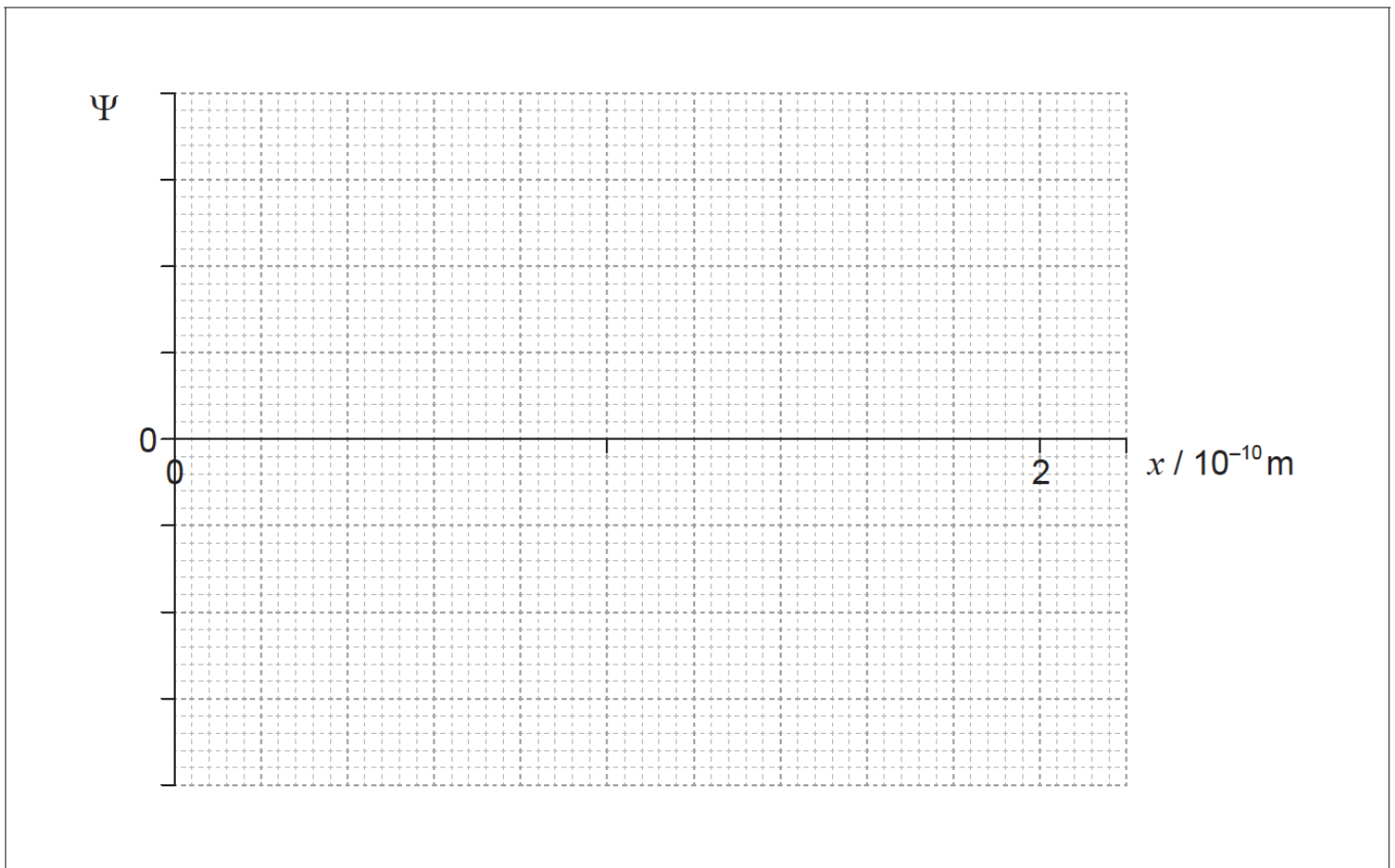

(iv) Identify the feature of your graph in (d)(iii) that gives the probability of finding the electron at a particular position and at a particular time.

## Markscheme

a. (i)  $l = \frac{\pi d^2 R}{4\rho}$  seen / correct substitution

into equation:  $24 = \frac{l \times 1.7 \times 10^{-8}}{\pi \times (0.15 \times 10^{-3})^2}$ ; } (condone use of  $r$  for  $\frac{d}{2}$  in first alternative)

99.7 (m);

Award [2] for bald correct answer.

Award [1 max] if area is incorrectly calculated, answer is 399 m if conversion to radius ignored, ie: allow ECF for second marking point if area is incorrect provided working clear.

(ii) electric field =  $\left(\frac{12}{99.7} =\right) 0.120 \text{ (Vm}^{-1}\text{)}$ ; (allow ECF from (a)(i))

electric force =  $(e \times E = 0.120 \times 1.6 \times 10^{-19} =) 1.92 \times 10^{-20} \text{ (N)}$ ;

acceleration =  $\left(\frac{F}{m} = \frac{1.92 \times 10^{-20}}{9.1 \times 10^{-31}} =\right) 2.11 \times 10^{10} \text{ (ms}^{-2}\text{)}$ ; } ( $5.27 \times 10^9$  if radius used in (a)(i) allow as ECF)

or

work done on electron =  $(Vq =) 12 \times 1.6 \times 10^{-19}$ ;

energy gained by electron =  $m_e \times a \times \text{distance travelled} = 9.11 \times 10^{-31} \times a \times 99.8$ ;

$2.11 \times 10^{10} \text{ (ms}^{-2}\text{)}$ ;

Award [3] for a bald correct answer.

(iii) free electrons collide with ions and other electrons;  
 speed decreases during collisions / transfer their kinetic during collisions;  
 kinetic energy transferred to heat / wires have resistance;  
 and speed increases/acceleration until next collision;

b. (i) use of total resistance =  $11\Omega$ ; (can be seen in second marking point)

$$\frac{1}{11} = \frac{1}{R} + \frac{1}{24};$$

$$20.3(\Omega);$$

(ii) as current is same in resistor network and cell and resistance is same, half of emf must appear across resistor network;  
 $6.0 \text{ (V)}$ ;

**or**

$$I = \frac{12}{(11+11)} = 0.545 \text{ (A)};$$

$$V=(0.545 \times 11) = 6.0 \text{ (V)};$$

*Other calculations are acceptable.*

*Award [2] for a bald correct answer.*

(iii) pd across  $2\Omega=6.0\text{V}$ ; (allow ECF from(b)(ii))

$$\left(\frac{V^2}{R} = \frac{36}{24} =\right) 1.5 \text{ (W)};$$

*Award [2] for a bald correct answer.*

c. measure of the probability of finding an electron (at a particular place and time);

d. (i)  $\Delta p = \frac{h}{4\pi\Delta x}$  and  $\Delta x=2.0 \times 10^{-10}$ ; (both needed)

$$2.64 \times 10^{-25} \text{ (Ns)}; \text{ (also accept } 5.28 \times 10^{-25} \text{ (Ns))}$$

*Award [2] for a bald correct answer.*

$$\text{(ii) } \lambda = \frac{h}{p} \left( = \frac{6.63 \times 10^{-34}}{2 \times 10^{-23}} \right);$$

$$3.3 \times 10^{-11} \text{ (m)};$$

*Award [2] for a bald correct answer.*

(iii)

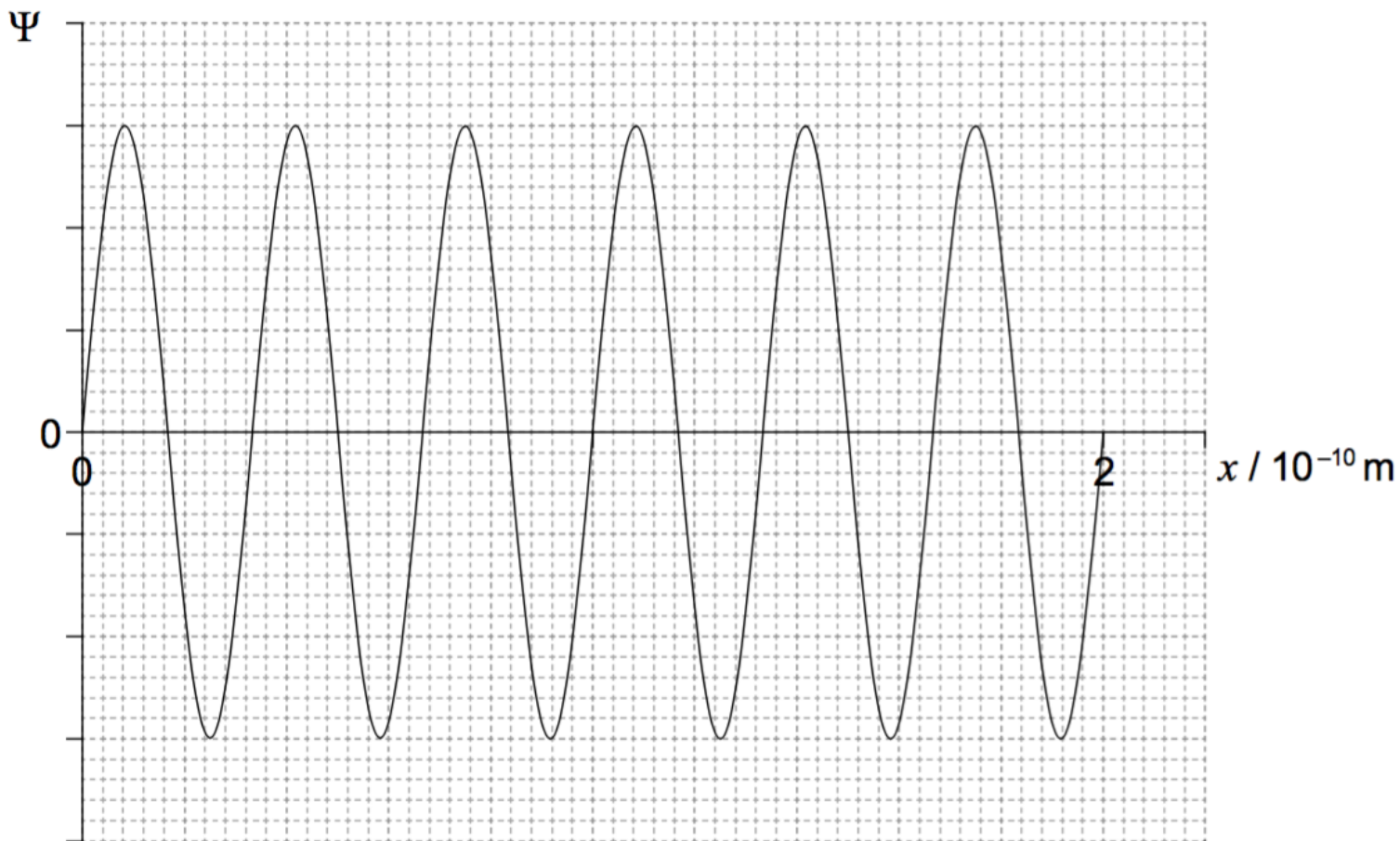

periodic behaviour shown anywhere between 0 nm and 0.2 nm;

6 loops/repetitions shown anywhere between 0 nm and 0.2 nm; } (allow ECF for division of  $2 \times 10^{-10}$  by answer to d(ii))

wavefunction completely fills from 0 nm to 0.2 nm and does not go beyond;

(iv) amplitude of  $\Psi$ /graph;  
squared;

## Examiners report

- a. [N/A]
- b. [N/A]
- c. [N/A]
- d. [N/A]